

DIMENSIONS TABLE

UNIT :mm

NOMINAL SIZE	d	DIN PN10			D	D ₁	D ₂	D ₃	L	H	H ₁	H ₂	H ₃	I	A ₁	A ₂	Number of handle wheel rotation	GEAR BOX MODEL No.
		C	n	h														
400 ^{mm} 16"	406	515	16	26	600	470	235	300	169	392	300	350	108	542	272	99	9.5	TYPE3

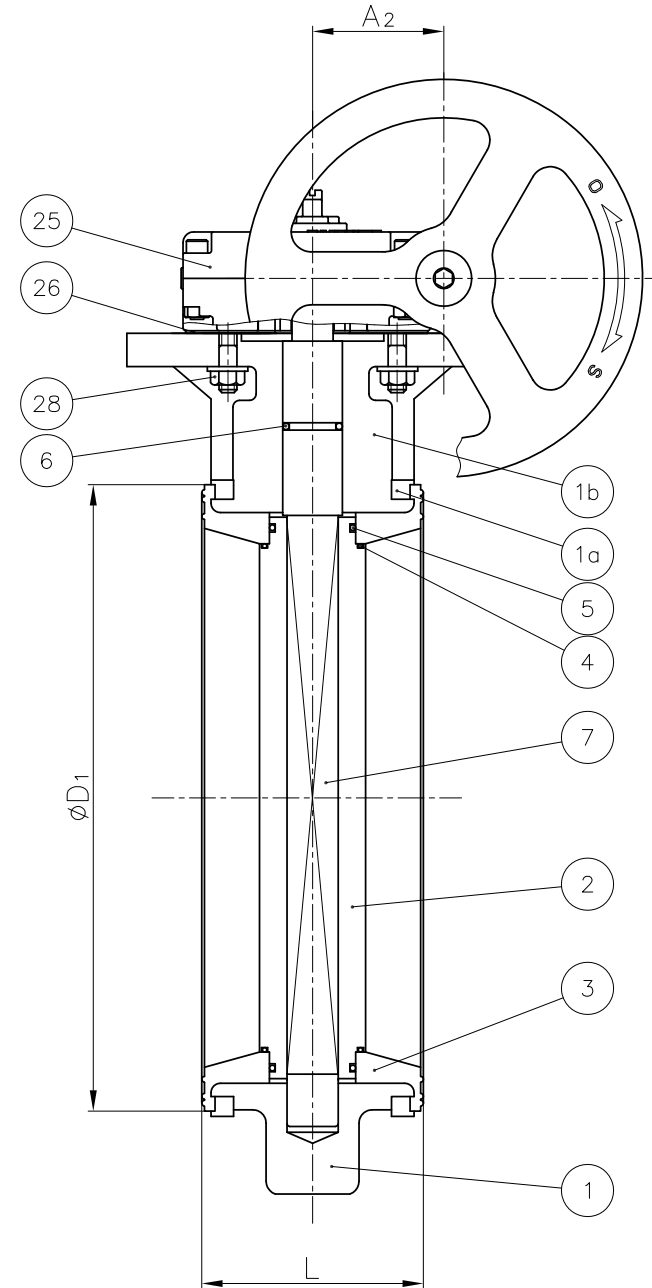
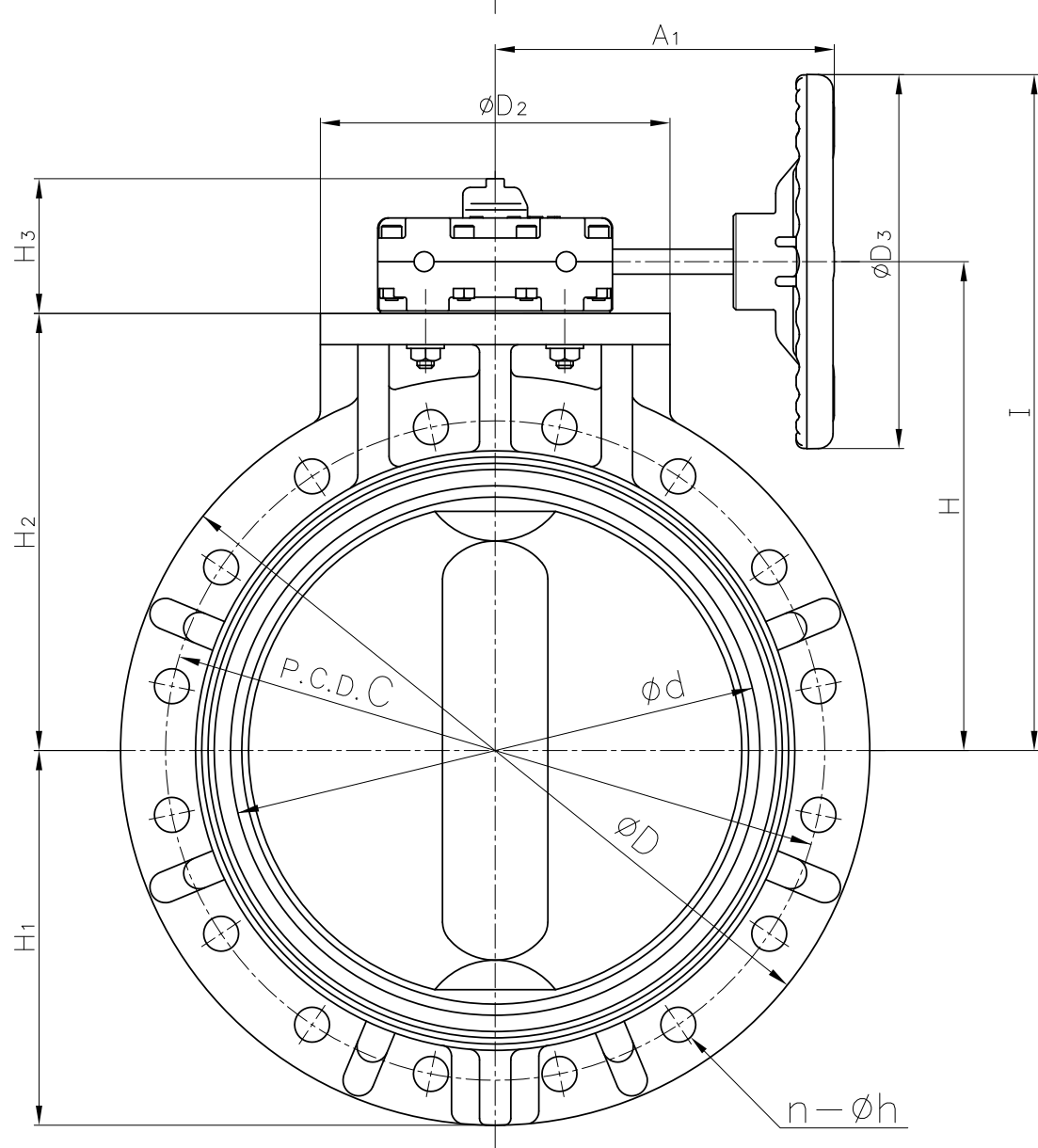
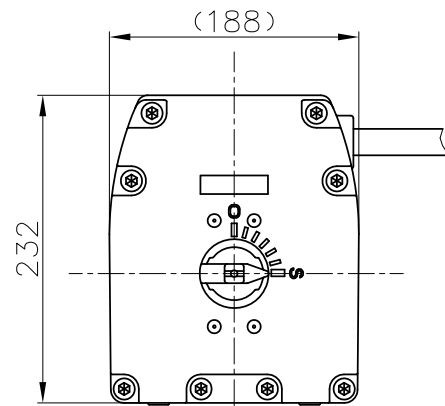

1a	RING	2	STEEL (SS400) WITH EPOXY POWDER COAT.	
28	BOLT (C)	4	STAINLESS STEEL (SUS304)	
26	GASKET (A)	1	EPDM	
25	GEAR BOX	1	PLASTIC etc.	
7	STEM	1	STAINLESS STEEL (SUS403)	
6	O-RING (C)	1	□EPDM □FKM □Others ()	
5	O-RING (B)	2		
4	O-RING (A)	2		
3	SEAT	1		
2	DISC	1	BODY/DISC □PP/PP □PVDF/PVDF	
1	BODY	1		
No.	DESCRIPTION	QTY.	MATERIAL	REMARKS
ITEM	BUTTERFLY VALVE (TYPE 56) ASS'Y SIDE GEAR TYPE :DIN PN10 400 ^{mm} (16")			
MODEL No.				
DRAWN	M.Yamamoto	DATE	SCALE	
CHECKED	H.Kawano	FEB.3.2009	~	
APPROVED	Y.Ozaki	DRAWING No.		
		56-M1010DE		2
SPECIAL ORDER No.				
ASAHI YUKIZAI CORPORATION				