

DIMENSIONS TABLE

Unit: mm

Nominal Size	d	ANSI Class 150				D ₁	L	t	H	H ₁	A	A ₁	P
		D	C	n	h								
50 ^{mm} 2"	52	152	120.5	4	19	172	200	16	469	77.5	256	229	1/4
80	3	78	191	152.5	4	19	250	240	18	562	92.5	261	1/4
100	4	100	229	190.5	8	19	280	290	18	611	105	266	1/4

NOTE. 1. Operating pressure: 0.4MPa G
 2. The shape and appearance of assembly differ a little with nominal size compared to this drawing

LIFT TABLE

Unit:mm

Nominal Size	PORT SIZE	PORT SIZE	
		S	L
50 ^{mm} 2"	2"	26	28
80	3	30	28
100	4	32	28

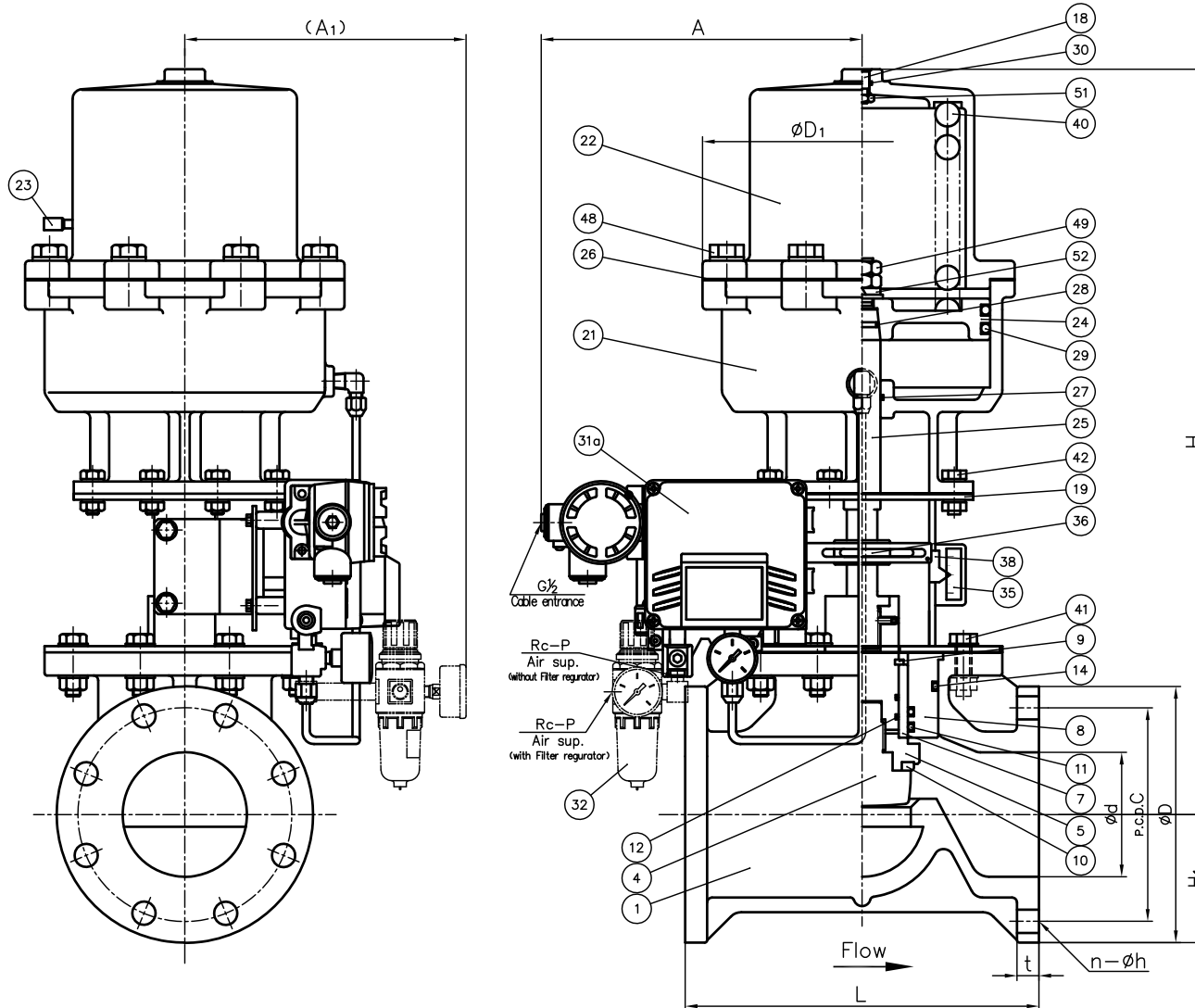

52	SPRING WASHER	1	SPRING STEEL	SUP
51	NUT (C)	1	STAINLESS STEEL	SUS304
49	NUT (A)	2	STAINLESS STEEL	SUS304
48	BOLT (G)	-	STAINLESS STEEL	SUS304
42	BOLT · NUT (B)	-	STAINLESS STEEL	SUS304
41	BOLT · NUT (A)	-	STAINLESS STEEL	SUS304
40	SPRING	1	SPRING STEEL	SUP
38	INDICATOR	1	STAINLESS STEEL	SUS304
36	COUPLING	1	COPPER ALLOY	C3604
35	INDICATOR SEAL	1	ACRYL	
32	FILTER REGULATOR	-	ZINC ALLOYS DIE CASTING (ZDC2) etc.	<input type="checkbox"/> ARU2-02-8A-G <input type="checkbox"/> nothing
31a	E-P POSITIONER	1	ALUMINIUM ALLOYS DIE CASTINGS (ADC12) etc.	YT-1000L
30	O-RING (H)	1	NBR	
29	O-RING (G)	2	NBR	
28	O-RING (F)	1	NBR	
27	O-RING (E)	1	NBR	
26	PACKING	1	NBR	
25	STEM	1	STAINLESS STEEL	SUS304
24	PISTON (B)	1	CAST ALUMINIUM ALLOY	AC5A
23	CHECK VALVE	1	COPPER ALLOY	C3604
22	CYLINDER COVER	1	CAST ALUMINIUM ALLOY (AC4C)	epoxy coat.
21	CYLINDER	1	CAST ALUMINIUM ALLOY (AC4C)	epoxy coat.
19	STAND	1	STAINLESS STEEL	SUS304
18	SEAL ROD	1	STAINLESS STEEL	SUS304
14	O-RING (D)	1	<input type="checkbox"/> EPDM <input type="checkbox"/> Viton [®] F <input type="checkbox"/> Viton [®] C <input type="checkbox"/> others	
12	O-RING (B)	2		
11	O-RING (A)	2		
10	SEAT	1	()	
9	STOP RING	1	PVDF	
8	BUSH GUIDE	1	PVC	
7	BUSH	1	PTFE	
5	PISTON (A)	1	PVC	
4	PLUG	1	PVC	
1	BODY	1	PVC	

No.	DESCRIPTION	QTY.	MATERIAL	REMARKS
ITEM	CONTROL VALVE PNEUMATIC ACTUATED MODEL TYPE AV ASSY AIR TO OPEN ANSI Class 150 : 50 ^{mm} (2") ~ 100 ^{mm} (4") with E-P POSITIONER, FILTER REGULATOR			
DRAWN	M.Iwakiri	DATE	SCALE	
CHECKED	H.Kawano	JUL.1.2019		
APPROVED	K.Koushou	DRAWING No.		
SPECIAL ORDER No.	CV-AA03AEm			<input type="checkbox"/>
ASAHI YUKIZAI CORPORATION				