

PORT SIZE 15,20,25mm

DIMENSIONS TABLE

Unit: mm

Nominal Size	d	DIN PN10					L	t	D <sub>1</sub>	H	H <sub>1</sub>	A	A <sub>1</sub>	Actuator Model
		D	C	n	h									
15mm	1/2"	16	95	65	4	14	160	12	102	335	51	146	110	MSP-6
25	1	25	115	85	4	14	184	14	116	354	63	146	110	MSP-6

NOTE. The shape and appearance of assembly differ a little with nominal size compared to this drawing.

LIFT (L) TABLE

Unit: mm

SIZE	QUALITY	PORT SIZE ØQ					
		6	8	10	15	20	25
15mm	EQ%	17	16	17	18	/	/
	Linear	16	16	15	16	/	/
25mm	EQ%	16.5	16	16	16	22	24
	Linear	16	16	14	15	19.5	25

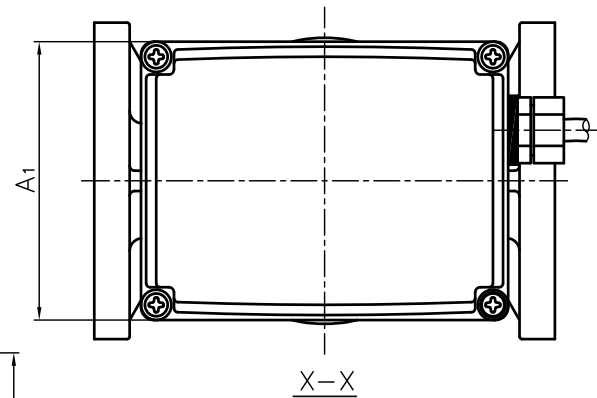

X-X

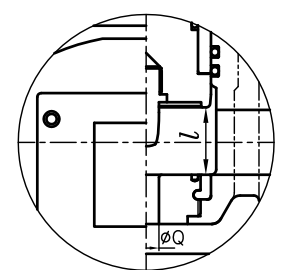

PORT SIZE 6,8,10mm

54	SCREW (B)	1	STAINLESS STEEL	SUS304
46	SCREW (A)	1	STAINLESS STEEL	SUS304
45	BOLT · NUT (E)	2sets	STAINLESS STEEL	SUS304
42	BOLT (A)	4	STAINLESS STEEL	SUS304
41	BOLT · NUT (A)	4sets	STAINLESS STEEL	SUS304
38	INDICATOR	1	STAINLESS STEEL	SUS304
35	INDICATOR SEAL	1	ACRYL	
20	ACTUATOR	1	ALUMINIUM ALLOY etc.	
19	STAND	1	STAINLESS STEEL	SUS304
16	NAME PLATE	2	ALUMINIUM	
12	O-RING (B)	1	□EPDM □Viflon <sup>®</sup> F	
11	O-RING (A)	2	□Viflon <sup>®</sup> C □others	
10	SEAT	1	( )	
9	STOP RING	1	PVDF	
7	BUSH	1	PTFE	
6	PISTON HOLDER	1	PVC	
5	PISTON (A)	1	PVC	
4	PLUG	1	PVC	
3	ORIFICE TUBE	1	PVC	
1	BODY	1	PVC	
No.	DESCRIPTION	QTY.	MATERIAL	REMARKS

ITEM	CONTROL VALVE ELECTRIC MODEL M TYPE ASS'Y DIN PN10 :15mm (1/2") · 25mm (1")		
DRAWN	M.Iwakiri	DATE	SCALE
CHECKED	H.Kawano	SEP.10.2019	~
APPROVED	K.Koushou	DRAWING No. CV-AE003DE	
SPECIAL ORDER No.	ASAHI YUKIZAI CORPORATION		