

DIMENSIONS TABLE

UNIT : mm

NOMINAL SIZE	d	ANSI Class 150					D1	D2	l (LIFT)	L		t		H	H1	S	S1	S2	P
		D	C	n	h	GRINNEL STANDARD				AV STANDARD	PVC C-PVC	PP PVDF							
65mm	2½"	67	178	139.5	4	19	216	255	34	—	250	22	23	353	61	85	M8	15	¼
80	3	78	191	152.5	4	19	216	255	42	263.5	280	22	23	376	63	100	M12	22	¼
100	4	100	229	190.5	8	19	232	271	50	328.5	340	22	24	428	78	120	M12	22	¼

NOTE. 1. Operation of permission pressure : 0.4~0.5MPaG

2. Diaphragms except EPDM and PTFE are available in FKM,VIFLON[®]C (FKM-C),VIFLON[®]F (FKM-F),CSM and NBR when required.

3. The shape and appearance of assembly differ a little with nominal size compared to this drawing.

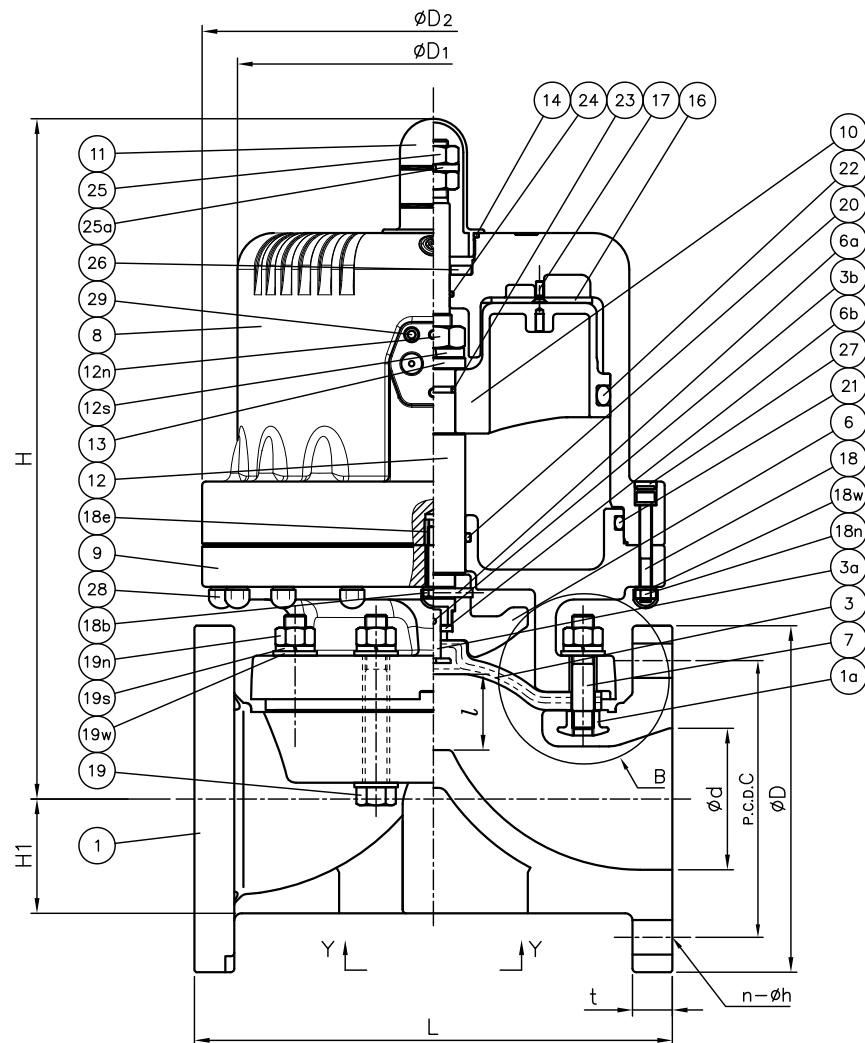

Face of Air Supply

Rc-P (b)

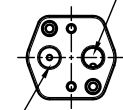

Rc-P (a)

Valve open : (a) Exhaust

: (b) Supply

Valve close : (a) Supply

: (b) Exhaust

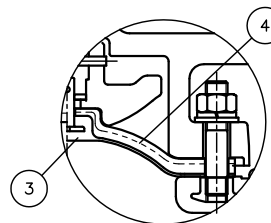

In case material of diaphragm is PTFE

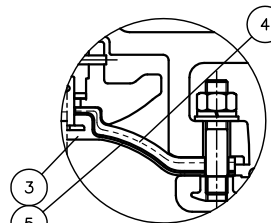

In case material of diaphragm is PTFE with cushion cover

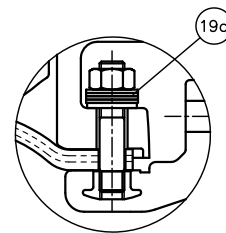

"B"Part

In case of PVDF Body

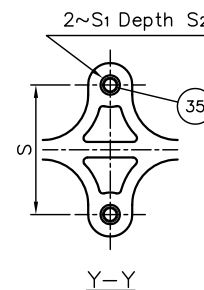

Y-Y

35	ENSAT FOR BODY	2	COPPER ALLOY (C3604)	
29	INSERTED METAL OF CYLINDER BODY	2	STAINLESS STEEL (SUS304)	
28	NUT CAP	—	PVC	
27	CAP	—	EPDM	
26	STOPPER BASE	1	STAINLESS STEEL (SUS304)	
25a	SPRING WASHER (No.25)	1	STAINLESS STEEL (SUS304)	
25	STOPPER	1Sets	STAINLESS STEEL (SUS304)	
24	O-RING (No.24)	1	NBR	
23	O-RING (No.23)	1	NBR	
22	O-RING (No.22)	1	NBR	
21	O-RING (No.21)	1	NBR	
20	O-RING (No.20)	1	NBR	
19w	WASHER (No.19)	12	STAINLESS STEEL (SUS304)	
19s	SPRING WASHER (No.19)	8	STAINLESS STEEL (SUS304)	
19n	NUT (No.19)	8	STAINLESS STEEL (SUS304)	
19c	CONICAL SPRING WASHER (No.19)	8Sets	STAINLESS STEEL (SUS304)	Use for PVDF Body
19	BOLT (No.19)	4	STAINLESS STEEL (SUS304)	
18w	WASHER (No.18)	—	STAINLESS STEEL (SUS304)	
18n	NUT (No.18)	—	STAINLESS STEEL (SUS304)	
18e	INSERTED NUT (No.18)	1	COPPER ALLOY (C3604)	
18b	BOLT (No.18)	1	STAINLESS STEEL (SUS304)	
18	CAP BOLT (No.18)	—	STAINLESS STEEL (SUS304)	
17	SCREW	4	STAINLESS STEEL (SUS304)	
16	SPRING BASE	1	PVC	
14	O-RING (No.14)	1	EPDM	
13	STEM WASHER	1	STAINLESS STEEL (SUS304)	
12s	SPRING WASHER (No.12)	1	STAINLESS STEEL (SUS304)	
12n	NUT (No.12)	1	STAINLESS STEEL (SUS304)	
12	STEM	1	STAINLESS STEEL (SUS304)	
11	GAUGE COVER	1	PC	
10	PISTON	1	PF+GF	
9	CYLINDER BONNET	1	PPG	
8	CYLINDER BODY	1	PPG	
7	STUD BOLT	4	STAINLESS STEEL (SUS304)	
6b	METAL OF COMPRESSOR	1	STAINLESS STEEL (SUS304)	
6a	COMPRESSOR PIN	1	STAINLESS STEEL (SUS304)	
6	COMPRESSOR	1	PVDF	
5	CUSHION COVER	1	□Nothing □PVDF	Use for PTFE Diaphragm
4	CUSHION	1	EPDM	Use for PTFE Diaphragm
3b	DIAPHRAGM PIN	1	STAINLESS STEEL (SUS304)	
3a	INSERTED METAL OF DIAPHRAGM	1	STAINLESS STEEL (SUS304)	
3	DIAPHRAGM	1	□EPDM □PTFE □Others ()	
1a	INSERTED NUT	4	COPPER ALLOY (C3604) STAINLESS STEEL (SUS304)	Use for PVC,C-PVC,PP Body Use for PVDF Body
1	BODY	1	□PVC □C-PVC □PP □PVDF	

No.	DESCRIPTION	QTY.	MATERIAL	REMARKS
ITEM	DIAPHRAGM VALVE (TYPE4) PNEUMATIC ACTUATED MODEL TYPE AP ASSY DOUBLE ACTING ANSI Class 150 : FLANGED END 65mm (2½") ~100mm (4") □ GRINNEL STANDARD, □ AV STANDARD			
DRAWN	E.Ozaki	DATE	SCALE	
CHECKED	H.Kawano	MAY.20.2019		
APPROVED	K.Koushou	DRAWING No.		
SPECIAL ORDER No.	D1-AA140AEm			
ASAHI YUKIZAI CORPORATION				