

DIMENSIONS TABLE

UNIT: inch

NOMINAL SIZE	d	ANSI Class 150					D <sub>1</sub>	L		t	l (LIFT)	H	H <sub>1</sub>	A	A <sub>1</sub>	A <sub>2</sub>	S	S <sub>1</sub>	S <sub>2</sub>	ACTUATOR MODEL
		D	C	n	h	GRINNELL STANDARD		AV STANDARD												
1/2"	15mm	0.63	3.50	2.38	4	0.62	2.13×2.60	4.25	4.33	0.43	0.39	15.98	0.77	3.98	3.19	5.51	0.98	M5	0.39	PSN-1
3/4"	20	0.79	3.88	2.75	4	0.62	2.13×2.60	5.88	4.72	0.51	0.39	16.06	0.69	3.98	3.19	5.51	0.98	M5	0.39	PSN-1
1"	25	0.98	4.25	3.12	4	0.62	2.64×3.15	5.88	5.12	0.59	0.47	16.26	0.73	3.98	3.19	5.51	0.98	M5	0.39	PSN-1
1 1/4"	32	1.26	4.62	3.50	4	0.62	2.64×3.15	6.38	-	0.63	0.47	16.38	0.89	3.98	3.19	5.51	0.98	M5	0.39	PSN-1
1 1/2"	40	1.57	5.00	3.88	4	0.62	4.25×4.25	6.94	7.09	0.63	0.83	18.27	1.08	4.33	3.54	5.91	1.77	M6	0.55	PSN-3
2"	50	2.05	6.00	4.75	4	0.75	4.84×4.84	7.94	8.27	0.79	0.98	18.62	1.42	4.33	3.54	5.91	1.77	M6	0.55	PSN-3

NOTE.

- Diaphragms except EPDM and PTFE are available in FKM, VIFLON<sup>®</sup> C (FKM-C), VIFLON<sup>®</sup> F (FKM-F), CSM and NBR when required.
- The shape and appearance of assembly differ a little with nominal size compared to this drawing.

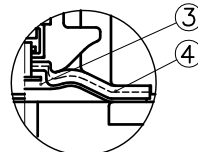
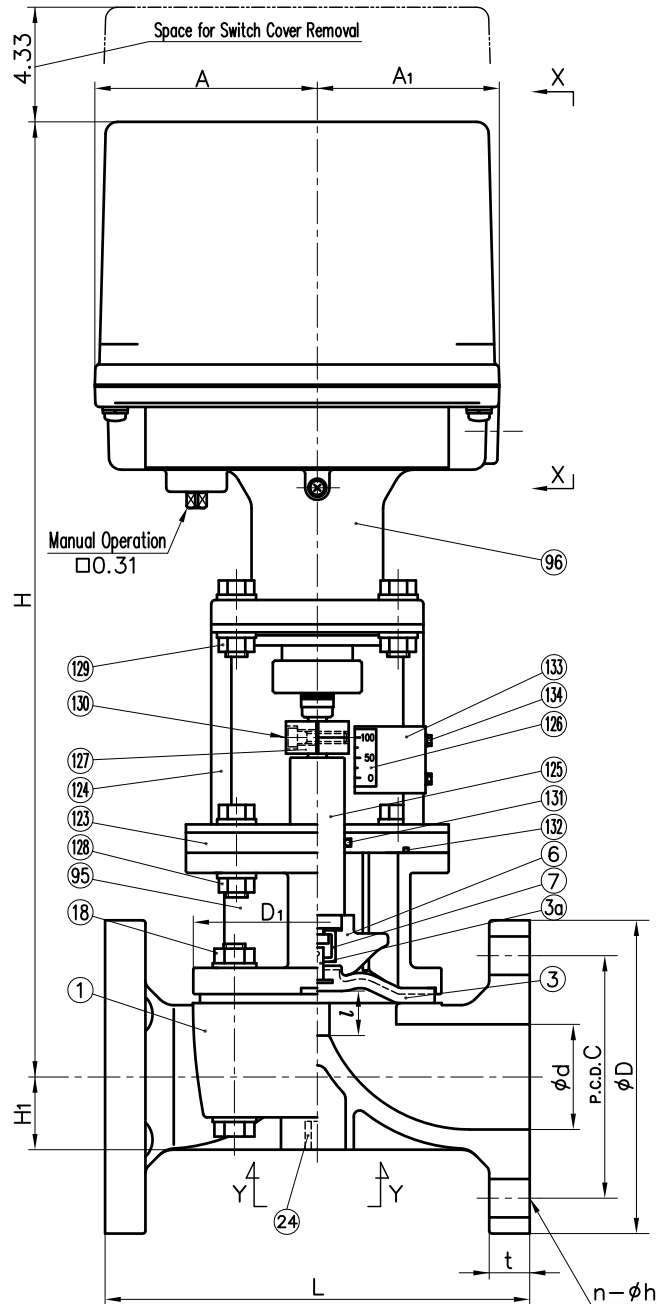

In case material of diaphragm is PTFE

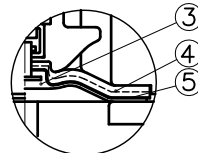

In case material of diaphragm is PTFE with cushion cover

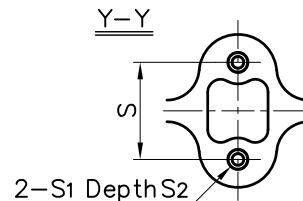
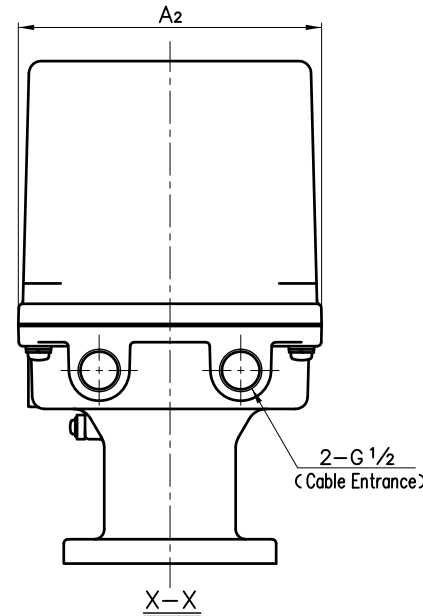

134	SCREW (F)	2	STAINLESS STEEL (SUS304)	
133	INDICATOR PLATE	1	STAINLESS STEEL (SUS304)	
132	O-RING (K)	1	NBR	
131	O-RING (J)	1	NBR	
130	BOLT (F)	2	STAINLESS STEEL (SUS304)	
129	BOLTO · NUT (F)	4 Sets	STAINLESS STEEL (SUS304)	
128	BOLTO · NUT (E)	4 Sets	STAINLESS STEEL (SUS304)	
127	JOINT	1	COPPER ALLOY (C3604)	
126	INDICATOR SEAL	1	ACRYL	
125	STEM (D)	1	COPPER ALLOY (C3604)	
124	STAND (A)	1	STAINLESS STEEL (SUS304)	
123	SPACER (A)	1	PVC	
96	ACTUATOR	1	ALUMINIUM etc.	Acryl Coat
95	BONNET	1	CAST ALUMINIUM ALLOY (AC4A)	Epoxy Coat
24	ENSAT FOR BODY	2	COPPER ALLOY (Equal to C3603)	
18	BOLT · NUT (A)	4 Sets	STAINLESS STEEL (SUS304)	
7	JOINT	1	STAINLESS STEEL (SUS304)	
6	COMPRESSOR	1	PVDF	
5	CUSHION COVER	1	□Noting □PVDF	Used for PTFE Diaphragm
4	CUSHION	1	EPDM	
3a	INSERTED METAL OF DIAPHRAGM	1	STAINLESS STEEL (SUS304)	
3	DIAPHRAGM	1	□EPDM □PTFE □Others ( )	
1	BODY	1	□PVC □C-PVC □PP □PVDF	

No.	DESCRIPTION	QTY.	MATERIAL	REMARKS
ITEM	DIAPHRAGM VALVE (TYPE14) ELECTRIC MODEL TYPE M ASS'Y ANSI Class 150: FLANGED END 1/2" (15mm) ~ 2" (50mm) □GRINNELL STANDARD, □AV STANDARD with E-E POSITIONER			

DRAWN	M.Iwakiri	DATE	SCALE
CHECKED	H.Kawano	FEB.12.2019	~
APPROVED	K.Koushou	DRAWING No. D1-AE003AE	

SPECIAL ORDER No. ASAHYUKIZAI CORPORATION