

DIMENSIONS TABLE

UNIT : mm

NOMINAL SIZE	d	JIS 10K					D ₁	D ₂	l ₁ (LIFT)	L	t		H	H ₁	H ₂	S	S ₁	S ₂
		D	C	n	h	PVC C-PVC					PP PVDF							
65mm 2 1/2"	67	175	140	4	19	175	220	34	250	22	23	266	188	61	85	11	20	
80	78	185	150	8	19	201	220	42	280	22	23	280	202	63	100	15	28	
100	100	210	175	8	19	241	257	50	340	22	24	329	241	78	120	15	28	

NOTE. 1. Diaphragms except EPDM and PTFE are available in FKM, VIFLON[®] C (FKM-C), VIFLON[®] F (FKM-F), CSM and NBR when required.
 2. The shape and appearance of assembly differ a little with nominal size compared to this drawing.

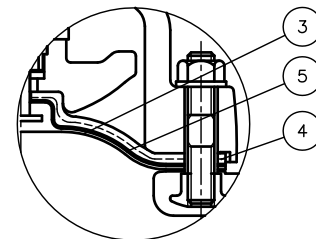
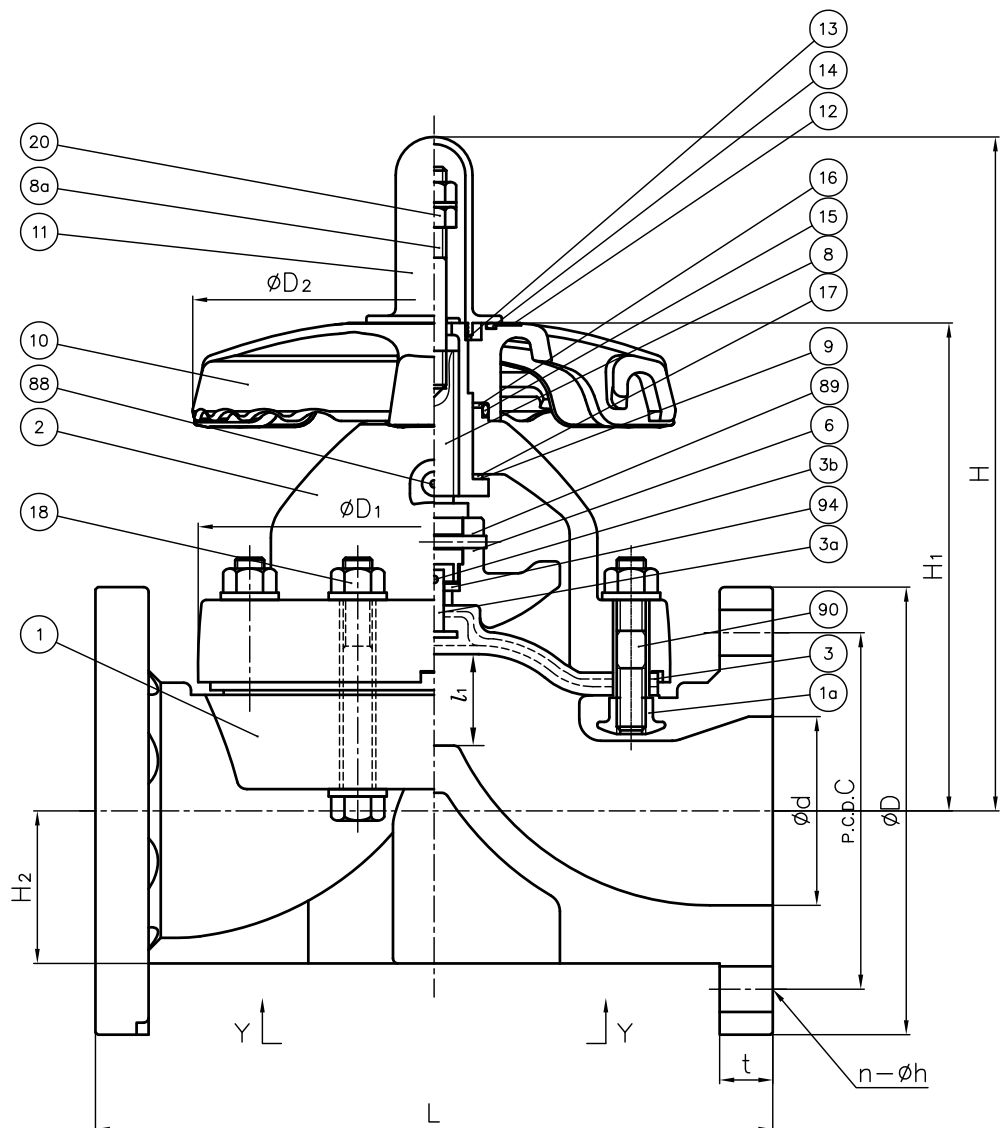

In case material of diaphragm is PTFE with cushion cover

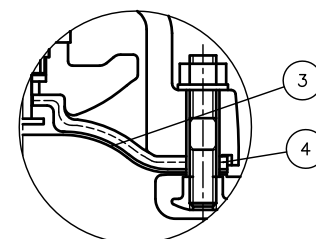

In case material of diaphragm is PTFE

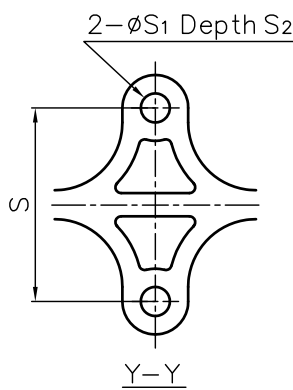

(Detail of Holes for Metallic Insert.)

1a	INSERTED NUT	4	COPPER ALLOY (C3604) STAINLESS STEEL (SUS304)	Used for PVC, C-PVC, PP Body Used for PVDF Body
94	METAL OF COMPRESSOR	1	STAINLESS STEEL	SUS304
90	STUD BOLT-NUT	4sets	STAINLESS STEEL	SUS304
89	COMPRESSOR PIN	1	STAINLESS STEEL	SUS304
88	GREASE NIPPLE	1	COPPER ALLOY C3604	
20	STOPPER (A)	1	STAINLESS STEEL	SUS304
18	BOLT&NUT (A)	4sets	STAINLESS STEEL	SUS304
17	THRUST RING (B)	1	UHMWPE	
16	THRUST RING (A)	1	UHMWPE	
15	O-RING (B)	1	EPDM	
14	O-RING (A)	1	EPDM	
13	RETAINING RING - C TYPE	1	STAINLESS STEEL	SUS304
12	NAME PLATE	1	PVC	
11	GAUGE COVER	1	PC	
10	HAND WHEEL	1	PP	
9	SLEEVE	1	COPPER ALLOY	C3604
8a	INDICATOR ROD	1	STAINLESS STEEL	SUS304
8	STEM	1	COPPER ALLOY	C3604
6	COMPRESSOR	1	PVDF	
5	CUSHION COVER	1	□nothing (standard) □PVDF	Used for PTFE Diaphragm
4	CUSHION	1	EPDM	Used for PTFE Diaphragm
3b	DIAPHRAGM PIN	1	STAINLESS STEEL	SUS304
3a	INSERTED METAL OF DIAPHRAGM	1	STAINLESS STEEL	SUS304
3	DIAPHRAGM	1	□EPDM □PTFE □others ()	
2	BONNET	1	□BODY/BONNET □PVC/PVC □C-PVC/PP □PP/PP	
1	BODY	1	□PVDF/PPG □PVDF/PVDF	

No.	DESCRIPTION	QTY.	MATERIAL	REMARKS
DIAPHRAGM VALVE (TYPE 14) ASS'Y JIS 10K : FLANGED END 65mm (2 1/2") ~ 100mm (4")				
DRAWN	M.Iwakiri	DATE	SCALE	
CHECKED	H.Kawano	FEB.12.2019		
APPROVED	K.Koushou	DRAWING No. D1-M1002JE		
SPECIAL ORDER No.	ASAHI YUKIZAI CORPORATION			