

DIMENSIONS TABLE

UNIT : inch

NOMINAL SIZE	d	ANSI Class 150				L	t		D1	D2	A	l	H	H1	S	S1	S2	S3	S4	S5	P	
		D	C	n	h		PVC	PP PVDF														
5" 125mm	4.92	10.00	8.50	8	0.88	16.14	0.87	0.94	12.60	12.01	5.91	2.36	20.00	5.63	0.59	12.20	13.78	11.02	12.60	0.91	¼	
6	150	5.83	11.00	9.50	8	0.88	18.90	0.94	1.06	15.16	15.16	7.68	2.76	22.28	5.83	0.63	14.17	15.75	12.20	13.78	0.91	¼

NOTE.

- Operation of permission pressure: 0.4~0.6MPa G
Valve open : Port (a) Exhaust, Port (b) Supply
Valve shut : Port (a) Supply, Port (b) Exhaust
- ③ Diaphragms except EPDM and PTFE are available in FKM, VIFLON[®] C (FKM-C), VIFLON[®] F (FKM-F), CSM and NBR when required.
- The shape and appearance of assembly differ a little with nominal size compared to this drawing.

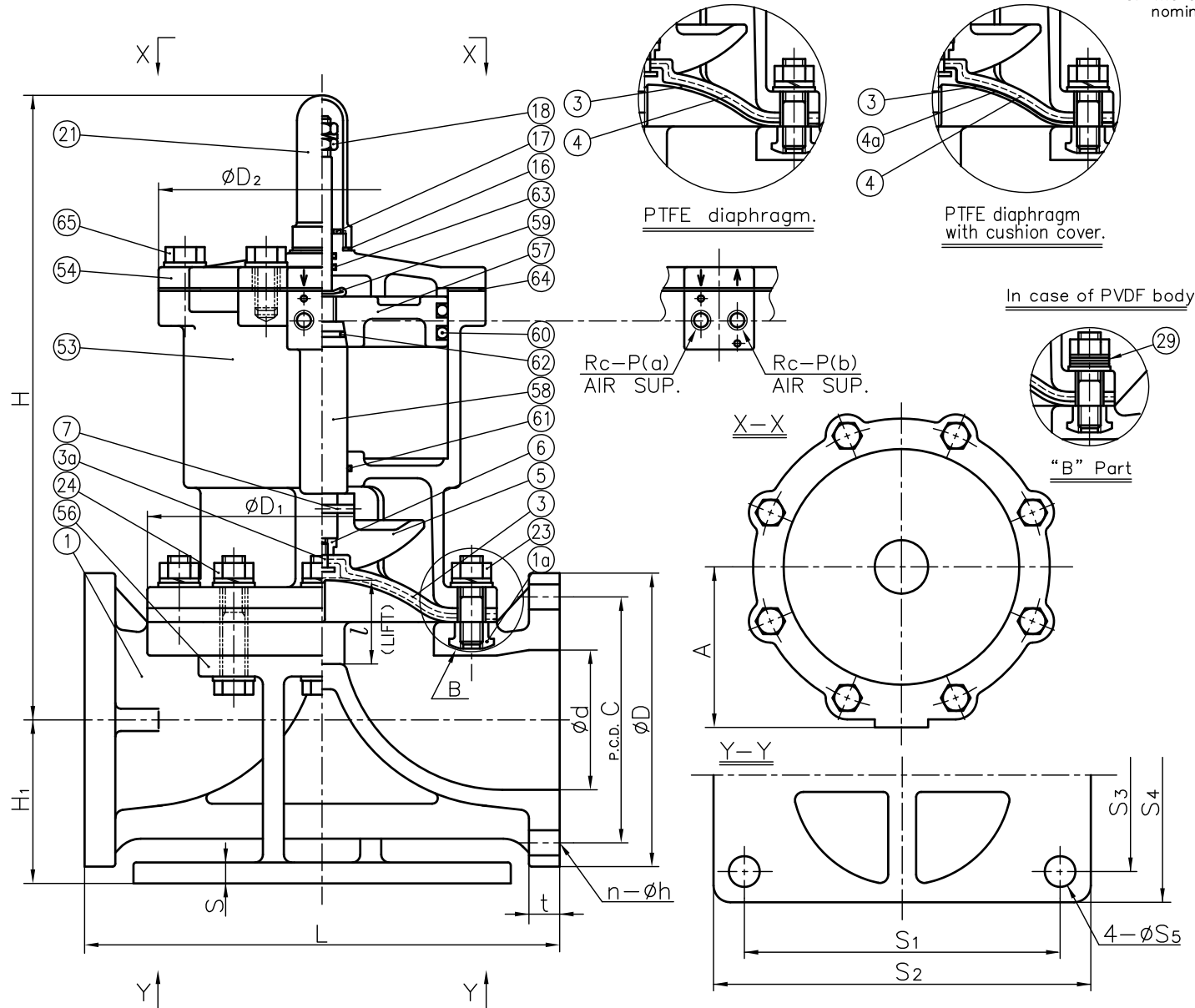

1a	INSERTED NUT	4	COPPER ALLOY (C3604)	Used for PVC & PP Body
			STAINLESS STEEL (SUS304)	Used for PVDF Body
65	BOLT (A)	-	STAINLESS STEEL (SUS304)	
64	SHEET GASKET (C)	1	NBR	
63	O-RING (G)	2	NBR	
62	O-RING (F)	1	NBR	
61	O-RING (E)	1	NBR	
60	O-RING (D)	2	NBR	
59	STEM PIN	1	SPRING STEEL (SUP)	
58	STEM (A)	1	STAINLESS STEEL (SUS304)	
57	PISTON	1	CAST ALUMINUM ALLOY (ACA5)	
56	STAND (A)	1	CAST ALUMINUM ALLOY (ACA6)	epoxy coat.
54	CYLINDER BONNET	1	CAST ALUMINUM ALLOY (ACA6)	epoxy coat.
53	CYLINDER BODY	1	CAST ALUMINUM ALLOY (ACA6)	epoxy coat.
29	CONICAL SPRING WASHER	-	STAINLESS STEEL (SUS304)	Used for PVDF Body
24	BOLT + NUT (A)	-	STAINLESS STEEL (SUS304)	
23	STUD BOLT + NUT	4 Sets	STAINLESS STEEL (SUS304)	
21	GAUGE COVER	1	PC	
18	STOPPER	1	STAINLESS STEEL (SUS304)	
17	SHEET RING	1	STAINLESS STEEL (SUS304)	
16	SHEET GASKET (A)	1	EPDM	
7	COMPRESSOR PIN	1	STAINLESS STEEL (SUS304)	
6	COMPRESSOR NUT	1	COPPER ALLOY (C3604)	
5	COMPRESSOR	1	PVDF	
4a	CUSHION COVER	1	□ Nothing □ PVDF	Used for PTFE Diaphragm
4	CUSHION	1	□ EPDM □ Others ()	Used for PTFE Diaphragm
3a	INSERTED METAL OF DIAPHRAGM (A)	1	STAINLESS STEEL (SUS304)	
3	DIAPHRAGM	1	□ EPDM □ PTFE □ Others ()	
1	BODY	1	□ PVC □ PP □ PVDF	

No.	DESCRIPTION	QTY.	MATERIAL	REMARKS
ITEM	DIAPHRAGM VALVE (TYPE 15) PNEUMATIC ACTUATED MODEL TYPE AV ASS'Y DOUBLE ACTING ANSI Class 150 : FLANGED END 5" (125mm) , 6" (150mm)			
DRAWN	M.Iwakiri	DATE	SCALE	
CHECKED	H.Kawano	FEB.12.2019		
APPROVED	K.Kaushou	DRAWING No.		
		D5-AA002AE		③
SPECIAL ORDER No.	ASAHI YUKIZAI CORPORATION			