

DIMENSIONS TABLE

Unit : mm

Nominal Size	d	DIN PN10					L	t		D ₁	D ₂	A	l	H	H ₁	S	S ₁	S ₂	S ₃	S ₄	S ₅	P
		D	C	n	h	PVC		PP/PVDF														
125mm	5"	125	250	210	8	18	400	22	23	320	305	150	60	508	143	15	310	350	280	320	23	¼
150	6	148	285	240	8	22	480	24	27	385	385	195	70	566	148	16	360	400	310	350	23	¼

NOTE.

- Operation of permission pressure: 0.4~0.6MPa G
Valve open : Port (a) Exhaust, Port (b) Supply
Valve shut : Port (a) Supply, Port (b) Exhaust
- ③ Diaphragms except EPDM and PTFE are available in FKM, VIFLON[®] C (FKM-C), VIFLON[®] F (FKM-F), CSM and NBR when required.
- The shape and appearance of assembly differ a little with nominal size compared to this drawing.

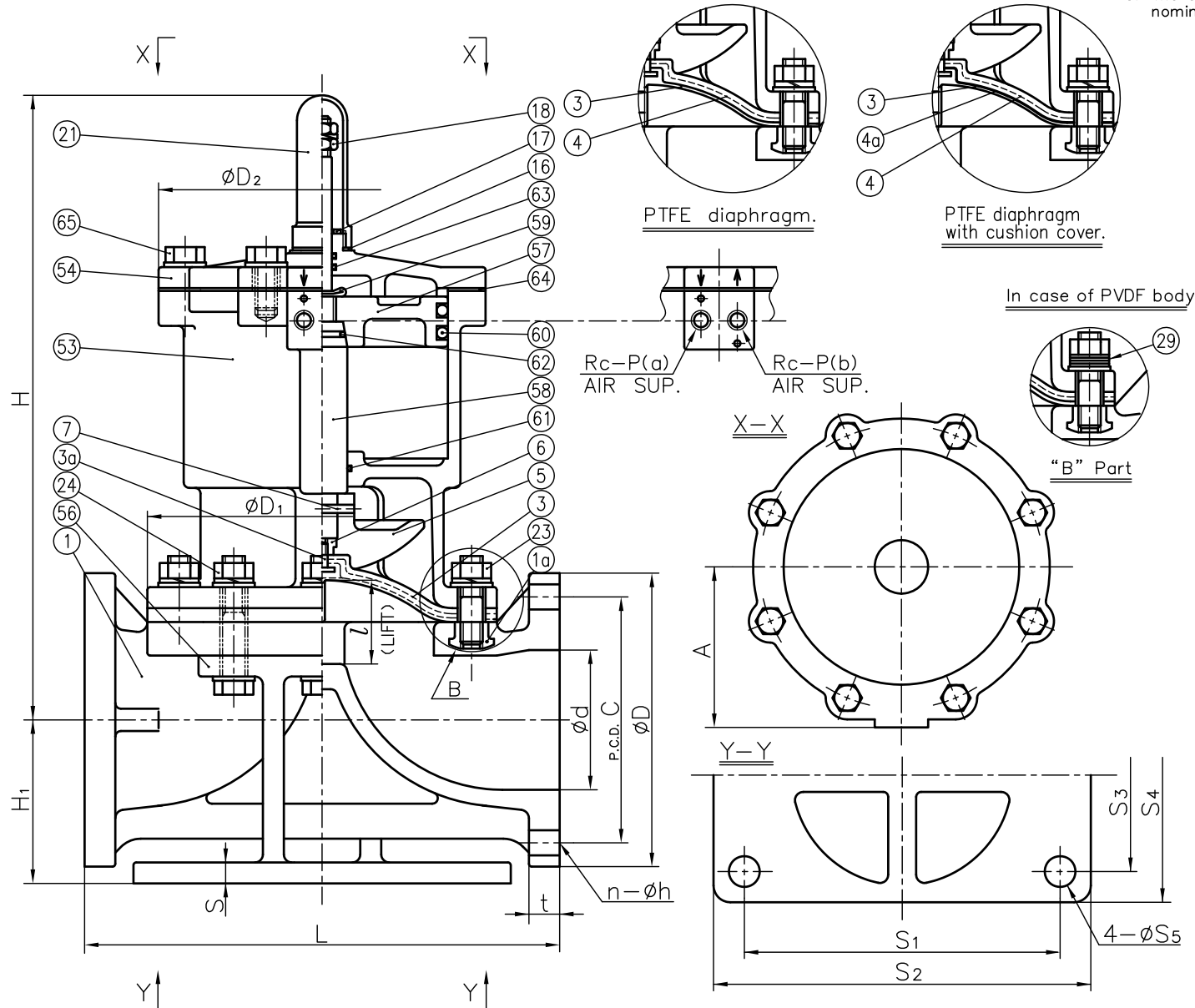

1a	INSERTED NUT	4	COPPER ALLOY (C3604)	Used for PVC & PP Body
			STAINLESS STEEL (SUS304)	Used for PVDF Body
65	BOLT (A)	—	STAINLESS STEEL (SUS304)	
64	SHEET GASKET (C)	1	NBR	
63	O-RING (G)	2	NBR	
62	O-RING (F)	1	NBR	
61	O-RING (E)	1	NBR	
60	O-RING (D)	2	NBR	
59	STEM PIN	1	SPRING STEEL (SUP)	
58	STEM (A)	1	STAINLESS STEEL (SUS304)	
57	PISTON	1	CAST ALUMINUM ALLOY (ACA5)	
56	STAND (A)	1	CAST ALUMINUM ALLOY (ACA6)	epoxy coat.
54	CYLINDER BONNET	1	CAST ALUMINUM ALLOY (ACA6)	epoxy coat.
53	CYLINDER BODY	1	CAST ALUMINUM ALLOY (ACA6)	epoxy coat.
29	CONICAL SPRING WASHER	—	STAINLESS STEEL (SUS304)	Used for PVDF Body
24	BOLT·NUT (A)	—	STAINLESS STEEL (SUS304)	
23	STUD BOLT·NUT	4 Sets	STAINLESS STEEL (SUS304)	
21	GAUGE COVER	1	PC	
18	STOPPER	1	STAINLESS STEEL (SUS304)	
17	SHEET RING	1	STAINLESS STEEL (SUS304)	
16	SHEET GASKET (A)	1	EPDM	
7	COMPRESSOR PIN	1	STAINLESS STEEL (SUS304)	
6	COMPRESSOR NUT	1	COPPER ALLOY (C3604)	
5	COMPRESSOR	1	PVDF	
4a	CUSHION COVER	1	□Nothing □PVDF	Used for PTFE Diaphragm
4	CUSHION	1	□EPDM □Others ()	Used for PTFE Diaphragm
3a	INSERTED METAL OF DIAPHRAGM (A)	1	STAINLESS STEEL (SUS304)	
3	DIAPHRAGM	1	□EPDM □PTFE □Others ()	
1	BODY	1	□PVC □PP □PVDF	

No.	DESCRIPTION	QTY.	MATERIAL	REMARKS
ITEM	DIAPHRAGM VALVE (TYPE 15) PNEUMATIC ACTUATED MODEL TYPE AV ASS'Y DOUBLE ACTING DIN PN10 : FLANGED END 125mm (5") , 150mm (6")			
DRAWN	M.Iwakiri	DATE	SCALE	
CHECKED	H.Kawano	FEB.12.2019		
APPROVED	K.Kaushou	DRAWING No. D5-AA002DE		
SPECIAL ORDER No.	ASAHI YUKIZAI CORPORATION			