

DIMENSIONS TABLE

UNIT : mm

NOMINAL SIZE	d	JIS 5K				JIS 10K				L	t		D ₁	D ₂	l	H	H ₁	S	S ₁	S ₂	S ₃	S ₄	S ₅	P	
		D	C	n	h	D	C	n	h		PVC	PP PVDF													
125mm	5"	125	235	200	8	19	250	210	8	23	410	22	24	320	455	60	690	143	15	310	350	280	320	23	¼
150	6	148	265	230	8	19	280	240	8	23	480	24	27	385	520	70	790	148	16	360	400	310	350	23	¼

NOTE.

- Operation of permission pressure: 0.4~0.6MPa G
- ③ Diaphragms except EPDM and PTFE are available in FKM, VIFLON® C (FKM-C), VIFLON® F (FKM-F), CSM and NBR when required.
- The shape and appearance of assembly differ a little with nominal size compared to this drawing.

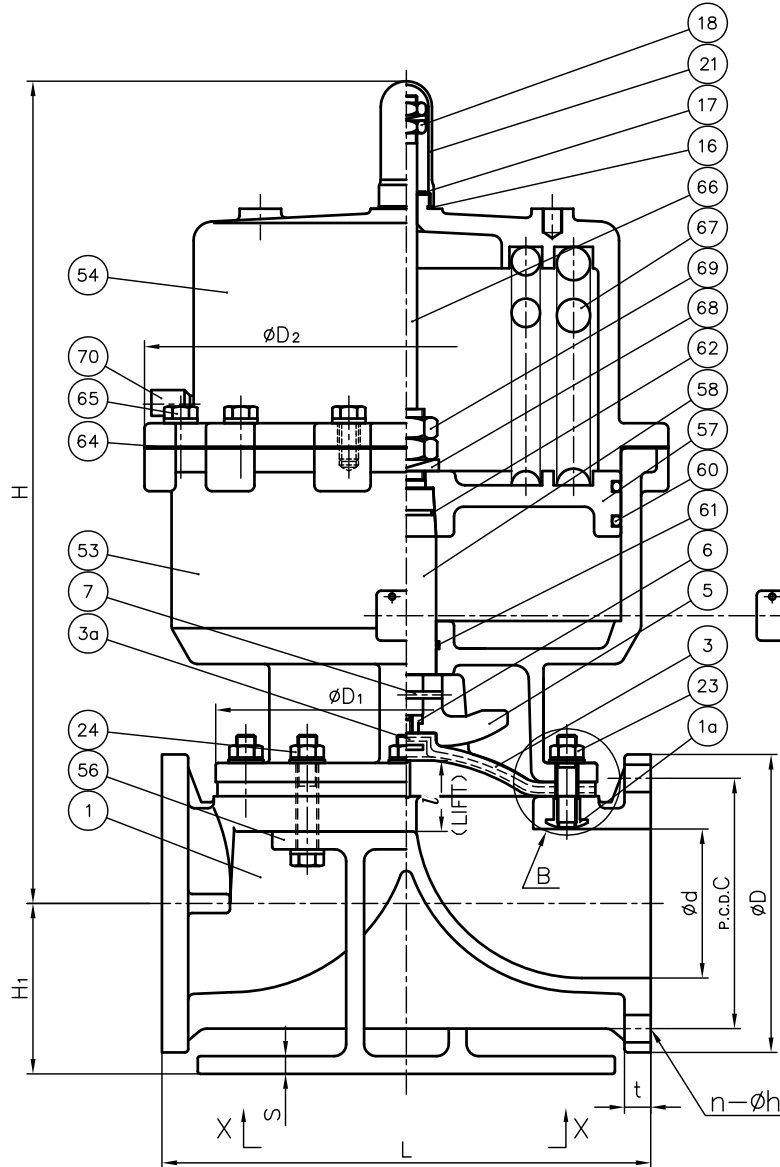

In case of PVDF body

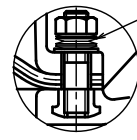

"B" Part

Rc-P AIR SUP.

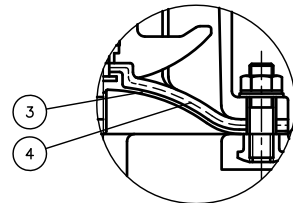

PTFE diaphragm.

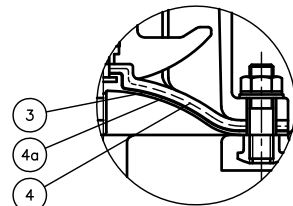

PTFE diaphragm with cushion cover.

X-X

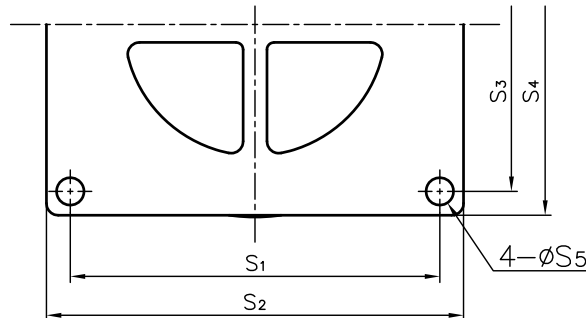

1a	INSERTED NUT	4	COPPER ALLOY (C3604)	Used for PVC & PP Body
			STAINLESS STEEL (SUS304)	Used for PVDF Body
70	CHECK VALVE FOR EXHAUST	1	COPPER ALLOY (C3604)	
69	LOCK NUT (B)	2	STAINLESS STEEL (SS400)	
68	SPRING WASHER	1	SPRING STEEL (SUP)	
67	SPRING	1	SPRING STEEL (SUP)	
66	INDICATOR ROD	1	STAINLESS STEEL (SUS304)	
65	BOLT (A)	-	STAINLESS STEEL (SUS304)	
64	SHEET GASKET (C)	1	NBR	
62	O-RING (F)	1	NBR	
61	O-RING (E)	1	NBR	
60	O-RING (D)	2	NBR	
58	STEM (A)	1	COPPER ALLOY (C3604)	
57	PISTON	1	CAST ALUMINUM ALLOY (AC6A)	
56	STAND (A)	1	CAST ALUMINUM ALLOY (AC6C)	epoxy coat.
54	CYLINDER BONNET	1	CAST ALUMINUM ALLOY (AC6C)	epoxy coat.
53	CYLINDER BODY	1	CAST ALUMINUM ALLOY (AC6C)	epoxy coat.
29	CONICAL SPRING WASHER	-	STAINLESS STEEL (SUS304)	Used for PVDF Body
24	BOLT · NUT (A)	-	STAINLESS STEEL (SUS304)	
23	STUD BOLT · NUT	4 Sets	STAINLESS STEEL (SUS304)	
21	GAUGE COVER	1	PC	
18	STOPPER	1	STAINLESS STEEL (SUS304)	
17	SHEET RING	1	STAINLESS STEEL (SUS304)	
16	SHEET GASKET (A)	1	EPDM	
7	COMPRESSOR PIN	1	STAINLESS STEEL (SUS304)	
6	COMPRESSOR NUT	1	COPPER ALLOY (C3604)	
5	COMPRESSOR	1	PVDF	
4a	CUSHION COVER	1	□Nothing □PVDF	Used for PTFE Diaphragm
4	CUSHION	1	□EPDM □Others ()	Used for PTFE Diaphragm
3a	INSERTED METAL OF DIAPHRAGM (A)	1	STAINLESS STEEL (SUS304)	
3	DIAPHRAGM	1	□EPDM □PTFE □Others ()	
1	BODY	1	□PVC □PP □PVDF	

No.	DESCRIPTION	QTY.	MATERIAL	REMARKS
ITEM	DIAPHRAGM VALVE (TYPE 15) PNEUMATIC ACTUATED MODEL TYPE AV ASSY AIR TO OPEN FLANGED END : □JIS 5K, □JIS 10K 125mm (5"), 150mm (6")			
DRAWN	E.Emmei	DATE	SCALE	
CHECKED	H.Kawano	MAY.23.2019		
APPROVED	K.Koushou	DRAWING No.		
		D5-AA003JE		△
SPECIAL ORDER No.	ASAHI YUKIZAI CORPORATION			