

In Case of PVDF Body

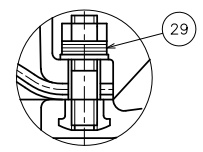

"B" Part

NOTE.

- Diaphragms except EPDM and PTFE are available in FKM, VIFLON<sup>®</sup> C (FKM-C), VIFLON<sup>®</sup> F (FKM-F), CSM and NBR when required.
- The shape and appearance of assembly differ a little with nominal size compared to this drawing.

No.	DESCRIPTION	QTY.	MATERIAL	REMARKS
1a	INSERTED NUT	4	COPPER ALLOY (C3604) STAINLESS STEEL (SUS304)	Used for PVC,C-PVC,PP Body Used for PVDF Body
113a	BOLT (F)	4	STAINLESS STEEL (SUS304)	
113	SPACER	1	SS400	Epoxy Coat.
75	BOLT (B)	4set	STAINLESS STEEL (SUS304)	
74	O-RING (H)	1	NBR	
73	ACTUATOR	1	CAST ALUMINIUM ALLOY (FC250 etc.)	Epoxy Coat.
72	STEM (B)	1	STAINLESS STEEL (SUS403)	
71	BONNET (B)	1	CAST ALUMINIUM ALLOY (AC4C)	Epoxy Coat.
56	STAND (A)	1	CAST ALUMINIUM ALLOY (AC4C)	Epoxy Coat.
29	CONICAL SPRING WASHER	12set	STAINLESS STEEL (SUS304)	Used for PVDF Body
24	BOLT · NUT	8set	STAINLESS STEEL (SUS304)	
23	STUD BOLT · NUT	4set	STAINLESS STEEL (SUS304)	
7	COMPRESSOR PIN	1	STAINLESS STEEL (SUS304)	
6	COMPRESSOR NUT	1	COPPER ALLOY (C3604)	
5	COMPRESSOR	1	PVDF	
4a	CUSHION COVER	1	<input type="checkbox"/> Nothing (standard) <input type="checkbox"/> PVDF	Used for PTFE Diaphragm
4	CUSHION	1	<input type="checkbox"/> EPDM <input type="checkbox"/> Others ( )	Used for PTFE Diaphragm
3a	INSERTED METAL OF DIAPHRAGM (A)	1	STAINLESS STEEL (SUS304)	
3	DIAPHRAGM	1	<input type="checkbox"/> EPDM <input type="checkbox"/> PTFE <input type="checkbox"/> Others ( )	
1	BODY	1	<input type="checkbox"/> PVC <input type="checkbox"/> PP <input type="checkbox"/> PVDF	

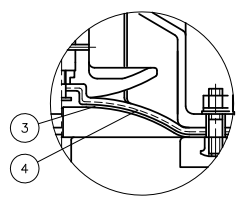
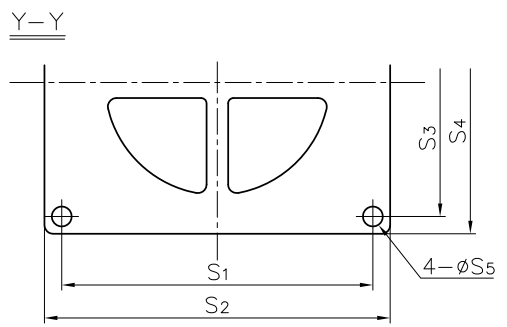
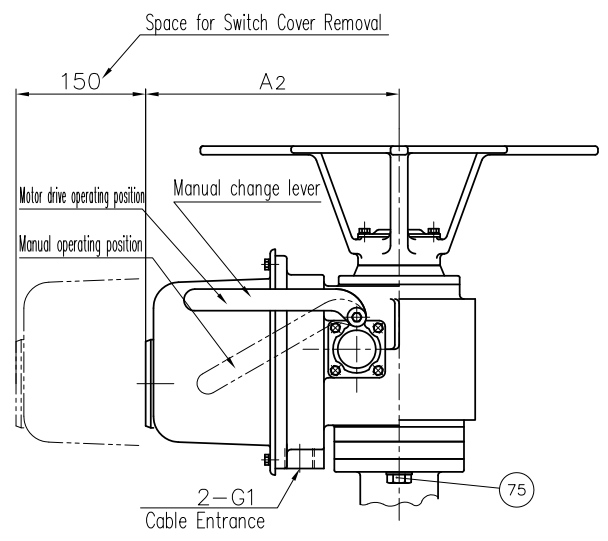
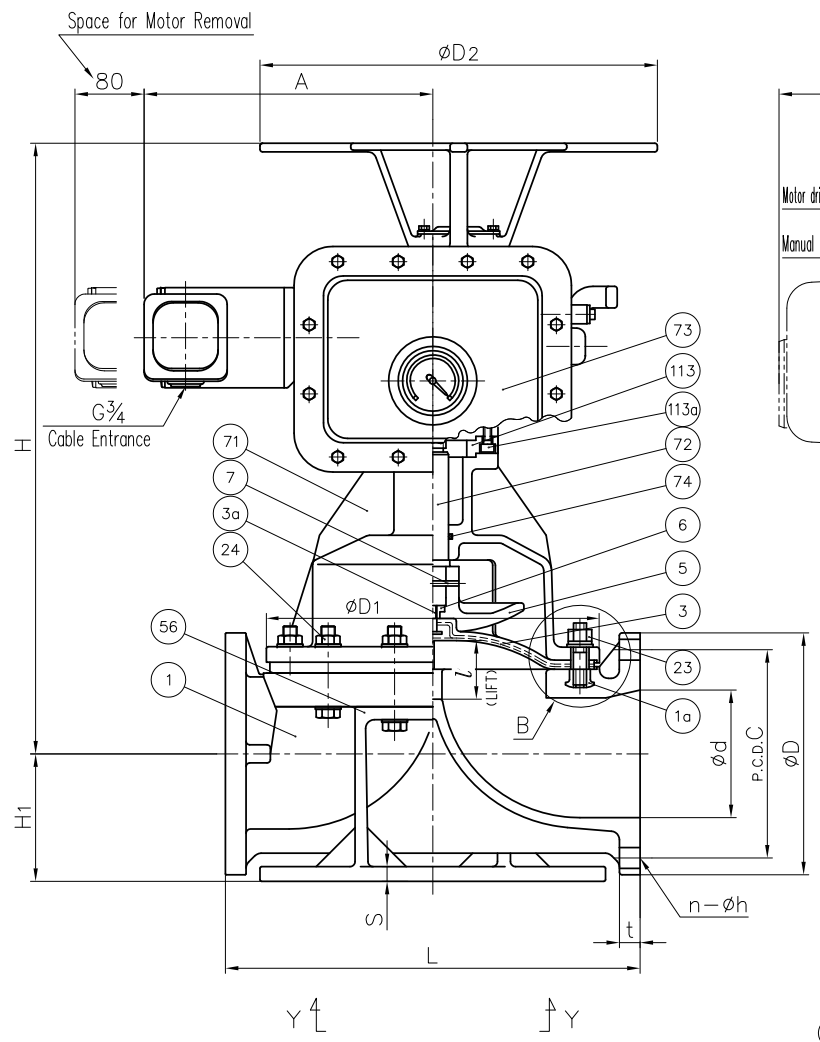

In case material of diaphragm is PTFE.

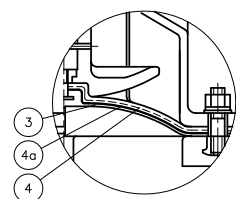

In case material of diaphragm is PTFE with cushion cover.

DIMENSIONS TABLE

NOMINAL SIZE	JIS 5K											JIS 10K				t		ACTUATOR MODEL										
	d	D	C	n	h	D	C	n	h	L	L	PVC C-PVC	PP PVDF	D1	D2	l	H	H1	A	A2	S	S1	S2	S3	S4	S5	Auto RECOVER TYPE	Manual RECOVER TYPE
150mm 6"	148	265	230	8	19	280	240	8	23	480	24	27	385	460	70	714	148	357	293	16	360	400	310	350	23	LTMD-01	LTKD-01	

UNIT : mm

ITEM	DIAPHRAGM VALVE (TYPE 15) ELECTRIC ACTUATED S TYPE ASSY □JIS 5K, □JIS 10K : FLANGED END 150mm (6")		
DRAWN	M.Iwakiri	DATE	SCALE
CHECKED	H.Kawano	AUG.20.2019	
APPROVED	K.Koushou	DRAWING No. D5-AE003JE	
SPECIAL ORDER No.	ASAHI YUKIZAI CORPORATION		