

DIMENSIONS TABLE

Nominal Size	d	FLANGED END																SOCKET END						THREADED END						Unit:inch									
		ANSI Class 150						PVC, C-PVC			PP, PVDF			d ₂	l	L		D ₁	H	A	A ₂	A ₃	A ₃ '	H ₁	S ₁	S ₂	S ₃	P	ACTUATOR TYPE										
		D	C	n	h	L	t	ASTM SCH80			PVC C-PVC	PVDF PP																											
		d ₁	d ₁ '	l	L	d ₁	l	L	PVC C-PVC	PVDF PP																													
1/2"	15mm	0.59	3.50	2.38	4	0.62	5.63	0.47	0.848	0.836	0.875	4.45	0.83	0.87	4.41	1/2 -14NPT	0.59	4.02	3.94	1.89	6.77	6.18	1.22	1.89	2.24	1.14	0.75	0.29	0.43	1/4	PP00S								
3/4	20	0.79	3.88	2.75	4	0.62	6.77	0.55	1.058	1.046	1.000	5.08	1.03	1.00	5.00	3/4 -14NPT	0.67	4.72	4.69	2.36	7.03	6.18	1.22	1.89	2.24	1.38	0.75	0.29	0.43	1/4	PP00S								
1	25	0.98	4.25	3.12	4	0.62	7.36	0.55	1.325	1.310	1.125	5.71	1.30	1.13	5.63	1 - 11 1/2 NPT	0.79	5.16	5.12	2.76	7.30	6.18	1.22	1.89	2.24	1.54	0.75	0.29	0.43	1/4	PP00S								
1 1/4	32	1.26	4.62	3.50	4	0.62	7.48	0.63	1.670	1.655	1.250	6.46	1.65	1.25	6.30	1 1/4 -11 1/2 NPT	0.87	5.91	5.75	3.23	7.66	6.18	1.22	1.89	2.24	1.85	1.18	0.35	0.59	1/4	PP00S								
1 1/2	40	1.57	5.00	3.88	4	0.62	8.35	0.63	1.912	1.894	1.375	7.24	1.89	1.37	7.05	1 1/2 -11 1/2 NPT	0.98	6.42	6.30	3.94	8.82	9.06	1.61	2.20	2.56	2.17	1.18	0.35	0.59	1/4	PP10S								
2	50	2.01	6.00	4.75	4	0.75	9.21	0.63	2.387	2.369	1.500	8.23	2.36	1.50	8.03	2 - 11 1/2 NPT	1.10	7.76	7.64	4.96	9.27	9.06	1.61	2.20	2.56	2.60	1.18	0.35	0.59	1/4	PP10S								

NOTE.

- Operating pressure: 0.4-0.6MPa G
Air to shut; Air-less open
- The shape and appearance of assembly differ a little with nominal size and material compared to this drawing.

FLANGED END

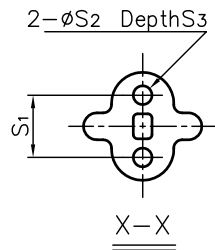
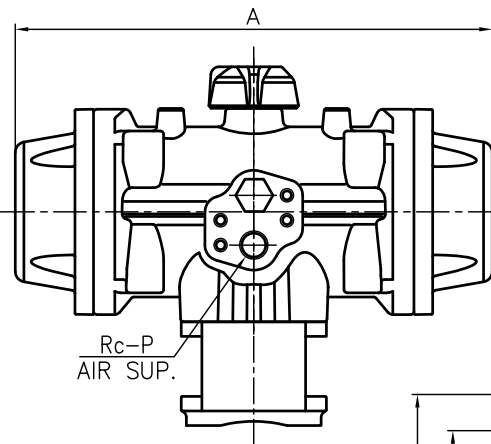

(Detail of Holes for Metallic Insert.)

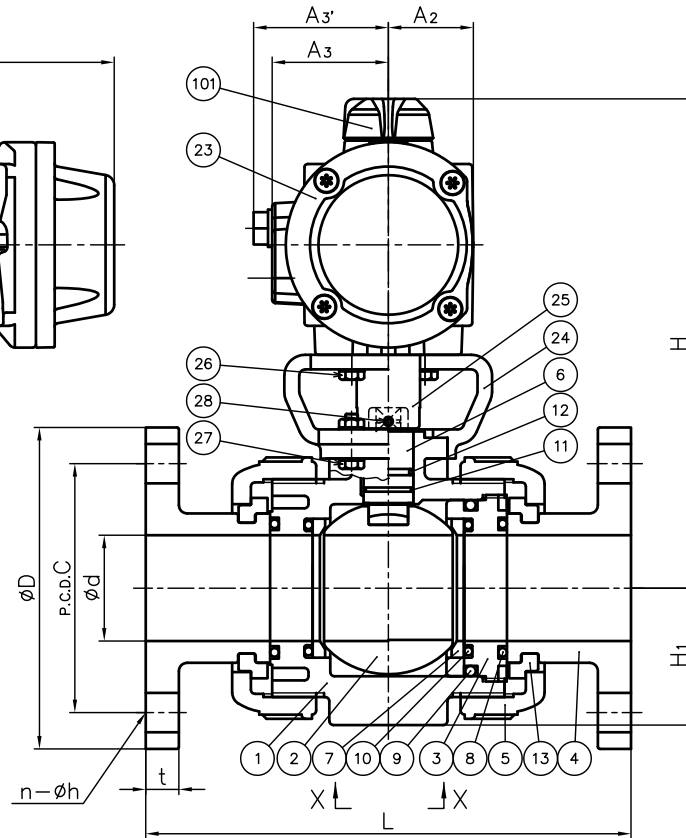

MODEL CLASSIFICATION TABLE

TYPE	MATERIAL
21ALPHA	PVC C-PVC
21	PP PVDF

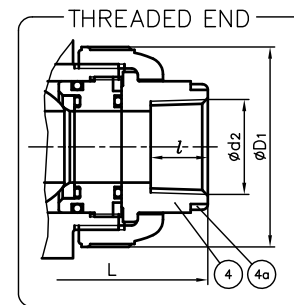
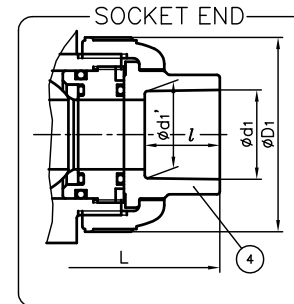

NO.	DESCRIPTION	QTY.	MATERIAL	REMARKS
4a	RING	2	STAINLESS STEEL (SUS304)	Used for C-PVC Body, Threaded End: 1/2"-1"
101	POSITION INDICATOR (A)	1	polyamide	PP00S, PP10S
28	SCREW (B)	2	STAINLESS STEEL (SUS304)	
27	BOLT · NUT (B)	4-sets	STAINLESS STEEL (SUS304)	
26	BOLT (A)	4	STAINLESS STEEL (SUS304)	
25	JOINT	1	COPPER ALLOY (C3604)	
24	STAND	1	PPG	
23	ACTUATOR	1	PA etc.	
13	STOP RING	2	PVDF	Used for Flanged End.
12	O-RING (E)	1		
11	O-RING (D)	1	□ EPDM □ FKM □ Others	
10	O-RING (C)	2		
9	O-RING (B)	1		
8	O-RING (A)	2		
7	SEAT	2	PTFE	
6	STEM	1		
5	UNION NUT	2		
4	END CONNECTOR	2	□ PVC □ C-PVC □ PP □ PVDF	
3	CARRIER	1		
2	BALL	1		
1	BODY	1		

ITEM	BALL VALVE (TYPE21 · 21ALPHA) PNEUMATIC MODEL AA TYPE ASSY AIR TO SHUT ANSI : □ FLANGED END, □ SOCKET END, □ THREADED END 1/2" (15mm) ~ 2" (50mm)		
DRAWN	M.Iwakiri	DATE	SCALE
CHECKED	H.Kawano	JUN.18.2019	~
APPROVED	K.Koushou	DRAWING No.	
SPECIAL ORDER No.	IB-AA218AE		
ASAHI YUKIZAI CORPORATION			