

DIMENSIONS TABLE

UNIT : mm

NOMINAL SIZE		JIS 10K																					ACTUATOR MODEL			
		d	C	h	N Number of Standard Bolt Holes	n Number of Through Bolt Holes	n1 Screw Holes		M	l ₁	l ₂	D	D ₁	D ₃	L	H	H ₁	H ₂	H ₃	H ₅	I	A		A ₂	A ₃	A ₄
1100 ^{mm}	44"	1080	1270	39	28	24	4	8	M36	77	55	1380	1195	290	300	883	780	840	585	258	1425	783	513	789	220	280
1200	48	1170	1380	39	32	28	4	8	M36	92	70	1488	1300	290	350	913	850	890	585	258	1475	783	513	789	220	280

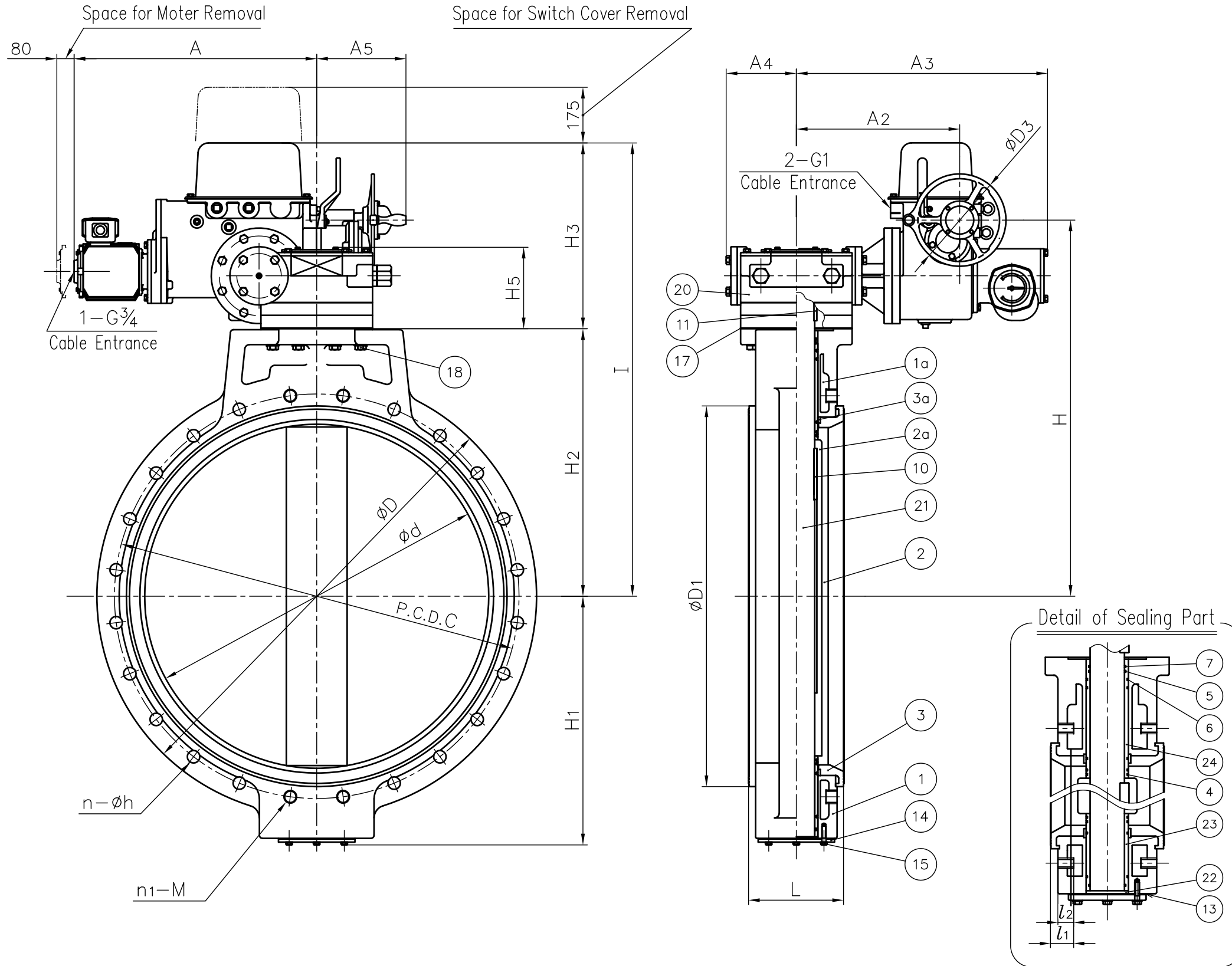

NOTE.

The shape and appearance of assembly differ a little with nominal size compared to this drawing.

3a	STABILIZATION RING	2	STAINLESS STEEL (SUS304)	
2a	INSERTED METAL OF DISC	1	DUCTILE IRON (FCD450)	
1a	INSERTED METAL OF BODY	1	DUCTILE IRON (FCD450)	
24	BUSH (B)	1	BRONZE CASTING (BC6)	
23	BUSH (A)	1	BRONZE CASTING (BC6)	
22	THRUST	1	BRONZE CASTING (BC6)	
21	STEM	1	STAINLESS STEEL (SUS403)	
20	ACTUATOR	1	DUCTILE IRON (FCD450) etc.	Tar Epoxy Coat.
18	BOLT (B)	8	STAINLESS STEEL (SUS304)	
17	GASKET (B)	1	NONAS SHEET	
15	BOLT (A)	6	STAINLESS STEEL (SUS304)	
14	STEM HOLDER (A)	1	STAINLESS STEEL (SUS304)	
13	GASKET (A)	1	NONAS SHEET	
11	KEY (B)	1	CORBON STEEL (S45C)	
10	KEY (A)	1	CORBON STEEL (S45C)	
7	O-RING (D)	1	NBR	
6	O-RING (C)	1	NBR	
5	O-RING (B)	2	EPDM	
4	O-RING (A)	8	EPDM	
3	SEAT	1	EPDM	
2	DISC	1	PDCPD	
1	BODY	1	PDCPD	

No.	DESCRIPTION	QTY.	MATERIAL	REMARKS
ITEM	PDCPD BUTTERFLY VALVE ELECTRIC ACTUATED S TYPE ASS'Y AUTO-RECOVERY TYPE JIS 10K 1100 ^{mm} (44"), 1200 ^{mm} (48")			
DRAWN	E.Ozaki	DATE	SCALE	
CHECKED	H.Kawano	FEB.22.2016	DRAWING No.	
APPROVED	H.Kourogi	RI-AE004JE		3

SPECIAL ORDER No. ASAHI YUKIZAI CORPORATION