

DIMENSIONS TABLE

NOMINAL SIZE	UNIT : mm																						
	SOCKET END										THREADED END												
	PVC,C-PVC					PP							L										
	d	d1	l	χ	L	d1	d1'	l	L	d2	l	PVC C-PVC	PP PVDF	D1	D2	D3	l1 (U/F)	H	H1	A3	S	S1	S2
15mm 1/2"	16	22.11	20	1/34	134	21.2	20.2	20	134	Rc 1/2	15	128	128	48	54 x 66	130	10	186	19.5	68	25	7	13
20 3/4"	20	26.13	24	1/34	156	26.2	25.2	23	154	Rc 3/4	17	148	148	60	54 x 66	130	10	188	17.5	68	25	7	13
25 1"	25	32.16	27	1/34	186	33.0	32.0	25	182	Rc 1	20	172	172	70	67 x 80	130	12	193	18.5	68	25	7	13
32 1 1/4"	32	38.19	30	1/34	200	-	-	-	-	Rc 1 1/4	22	188	188	82	67 x 80	130	12	197	22.5	68	25	7	13
40 1 1/2"	40	48.21	37	1/37	271	47.0	46.0	28	253	Rc 1 1/2	25	245	245	100	108 x 108	174	21	293	27.5	92	45	9	15
50 2"	52	60.25	42	1/37	303	59.0	58.0	28	275	Rc 2	28	281	278	106	123 x 123	174	25	302	36	92	45	9	15

NOTE.  
 1. Operation of permission pressure: 0.4~0.6MPa G  
 Air to open : 25~50<sup>mm</sup> : 0.45~0.6MPa G (only fluid pressure is 0)  
 2. Double Acting : Valve open : Port (a) Exhaust Port (b) Supply  
 Valve shut : Port (a) Supply Port (b) Exhaust  
 Air To Open : Valve open : Port (a) Supply  
 Valve shut : Port (b) Exhaust  
 Air To Shut : Valve open : Port (a) Exhaust  
 Valve shut : Port (a) Supply  
 3. Diaphragms except EPDM and PTFE are available in FKM, VIFLON<sup>TM</sup>C (FKM-C), VIFLON<sup>TM</sup>F (FKM-F), CSM and NBR when required.  
 4. The shape and appearance of assembly differ a little with nominal size compared to this drawing.

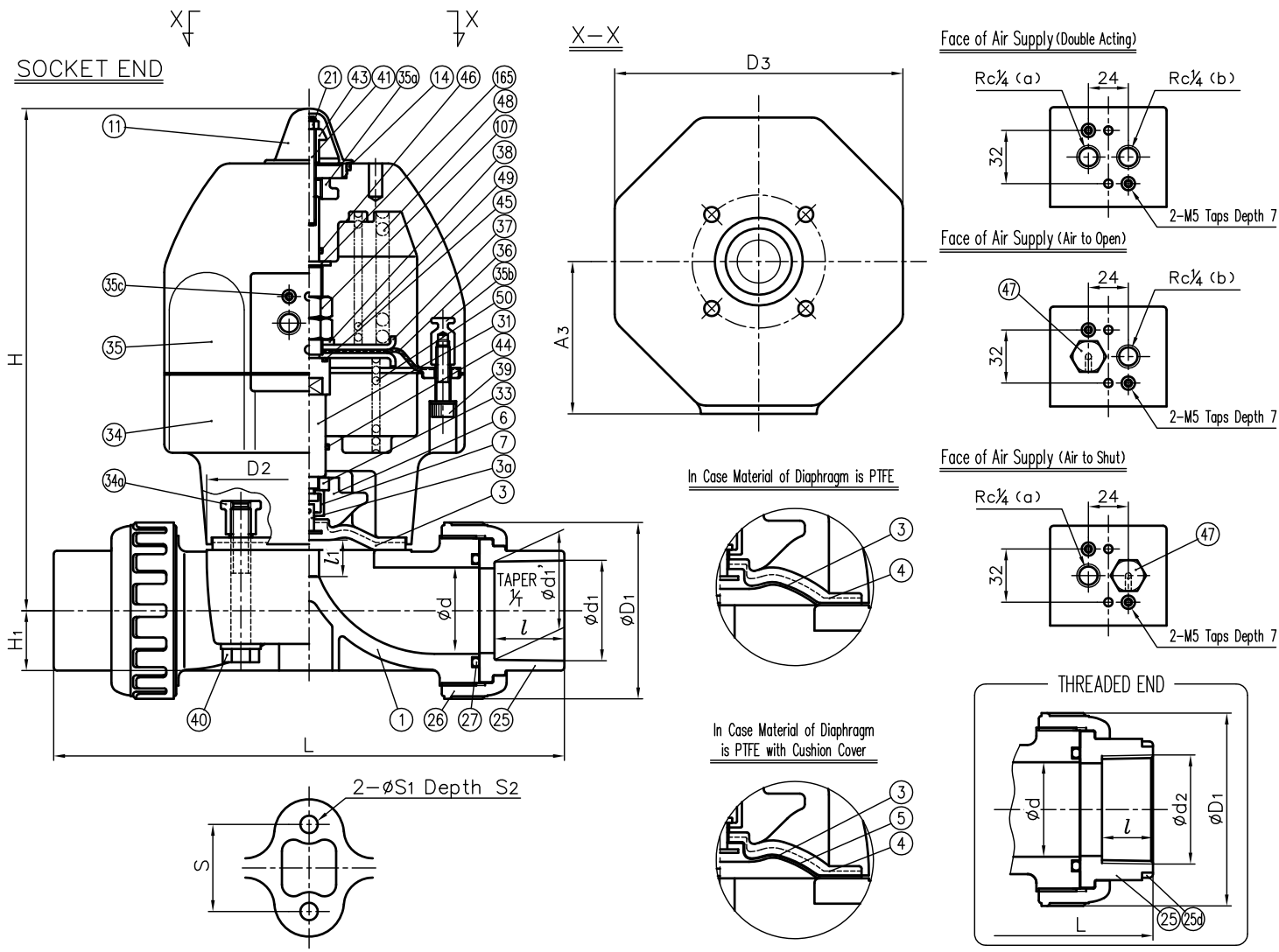

25d	RING	2	STAINLESS STEEL (SUS304)	Used for C-PVC Body, Threaded End : 15~25 <sup>mm</sup>
165	WASHER	1	STAINLESS STEEL SUS304	
107	LOCK NUT	2	STAINLESS STEEL SUS304	
50	SPRING (C)	1	SPRING STEEL (SWOSM-B)	Used for Air to Shut
49	SPRING (B)	1	SPRING STEEL (SWOSM-B)	Used for Air to Open
48	SPRING (A)	1	SPRING STEEL (SWOSM-B)	Used for Air to Open
47	NIPPLE	1	COPPER ALLOY (C3604)	Used for Air to Shut and Air to Open
46	O-RING (F)	1	NBR	
45	O-RING (E)	1	NBR	
44	O-RING (D)	1	NBR	
43	STOPPER	1	STAINLESS STEEL SUS304	
41	INDICATING LOD	1	STAINLESS STEEL SUS304	
40	BOLT (B)	4	STAINLESS STEEL SUS304	
39	BOLT (A)	8	STAINLESS STEEL SUS304	
38	CONICAL SPRING WASHER (B)	1	STAINLESS STEEL SUS304	
37	CYLINDER DIAPHRAGM PLATE	2	STAINLESS STEEL SUS304	
36	CYLINDER DIAPHRAGM	1	NBR	
35c	SCREWED METAL OF CYLINDER BONNET	2	STAINLESS STEEL SUS303	
35b	INSERTED METAL OF CYLINDER BONNET (B)	8	COPPER ALLOY C3604	
35a	INSERTED METAL OF CYLINDER BONNET (A)	1	STAINLESS STEEL SUS304	
35	CYLINDER BONNET	1	PPG	
34a	INSERTED METAL OF CYLINDER BODY	4	COPPER ALLOY C3604	
34	CYLINDER BODY	1	PPG	
33	COMPRESSOR PUSHING PLATE	1	COPPER ALLOY C3604	
31	STEM	1	COPPER ALLOY C3604	
27	O-RING (C)	2	EPDM □Others ( )	
21	NUT	1	STAINLESS STEEL SUS304	
14	O-RING (A)	1	EPDM	
11	GAUGE COVER	1	PC	
7	JOINT	1	STAINLESS STEEL SUS304	
6	COMPRESSOR	1	PVDF	
5	CUSHION COVER	1	□ Nothing □ PVDF	Used for PTFE Diaphragm
4	CUSHION	1	EPDM	
3a	INSERTED METAL OF DIAPHRAGM	1	STAINLESS STEEL SUS304	
3	DIAPHRAGM	1	□ EPDM □ PTFE □ Others ( )	
26	UNION NUT	2	□ PVC	
25	END CONNECTOR	2	□ C-PVC □ PP	
1	BODY	1	□ PVDF	

No.	DESCRIPTION	QTY.	MATERIAL	REMARKS
ITEM	T.U. DIAPHRAGM VALVE (TYPE14) PNEUMATIC ACTUATED MODEL TYPE AN ASSY □DOUBLE ACTING, □AIR TO OPEN, □AIR TO SHUT JIS : □SOCKET END, □THREADED END 15 <sup>mm</sup> (1/2") ~ 50 <sup>mm</sup> (2")			
DRAWN	E.Emmei	DATE	SCALE	
CHECKED	H.Kawano	FEB.12.2019		
APPROVED	K.Koushou	DRAWING No.		
		T1-AA001JE		
SPECIAL ORDER No.	ASAHI YUKIZAI CORPORATION			