

DIMENSIONS TABLE

UNIT: mm

NOMINAL SIZE	d	SOCKET END							THREADED END							D ₁	D ₂	l ₁ (LIFT)	H	H ₁	A	A ₁	A ₂	A ₃	E	S	S ₁	S ₂	ACTUATOR MODEL
		PVC,C-PVC				PP,PVDF (IPS)			d ₂	l	L		PVC C-PVC	PP PVDF															
		ASTM SCH80		L	d ₁	l	L	PVC C-PVC			PP PVDF																		
		d ₁	d ₁ '									l			L														
15mm	1/2"	16	21.54	21.23	22.23	139	21.08	22.1	138	1/2 - 14NPT	15	128	128	48	54 x 66	10	284	19.5	80	130	84	80	5	25	M5	10	ED-11H		
20	3/4"	20	26.87	26.57	25.4	157	26.16	25.4	155	3/4 - 14NPT	17	148	148	60	54 x 66	10	286	17.5	80	130	84	80	5	25	M5	10	ED-11H		
25	1"	25	33.66	33.27	28.58	186	33.02	28.7	184	1 - 1 1/2 NPT	20	172	172	70	67 x 80	12	291	18.5	80	130	84	80	5	25	M5	10	ED-11H		
32	1 1/4"	32	42.42	42.04	31.75	202	41.91	31.75	198	1 1/4 - 1 1/2 NPT	22	188	188	82	67 x 80	12	294.5	22.5	80	130	84	80	5	25	M5	10	ED-11H		
40	1 1/2"	40	48.56	48.11	34.93	266	48.01	34.80	261	1 1/2 - 1 1/2 NPT	25	245	245	100	110 x 110	21	302.2	27.5	80	130	84	80	5	45	M6	14	ED-11H		
50	2"	52	60.63	60.17	38.1	293	59.94	38.1	293	2 - 1 1/2 NPT	28	281	278	106	128 x 128	25	311.2	36	80	130	84	80	5	45	M6	14	ED-11H		

SOCKET END

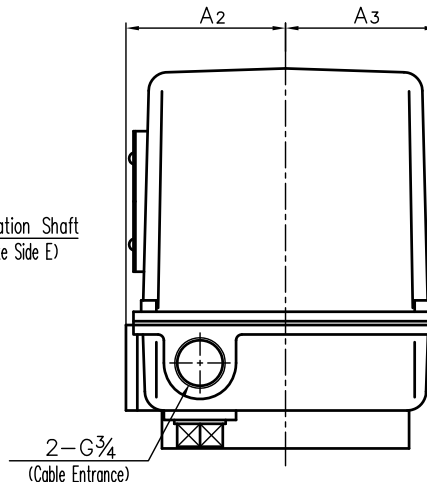
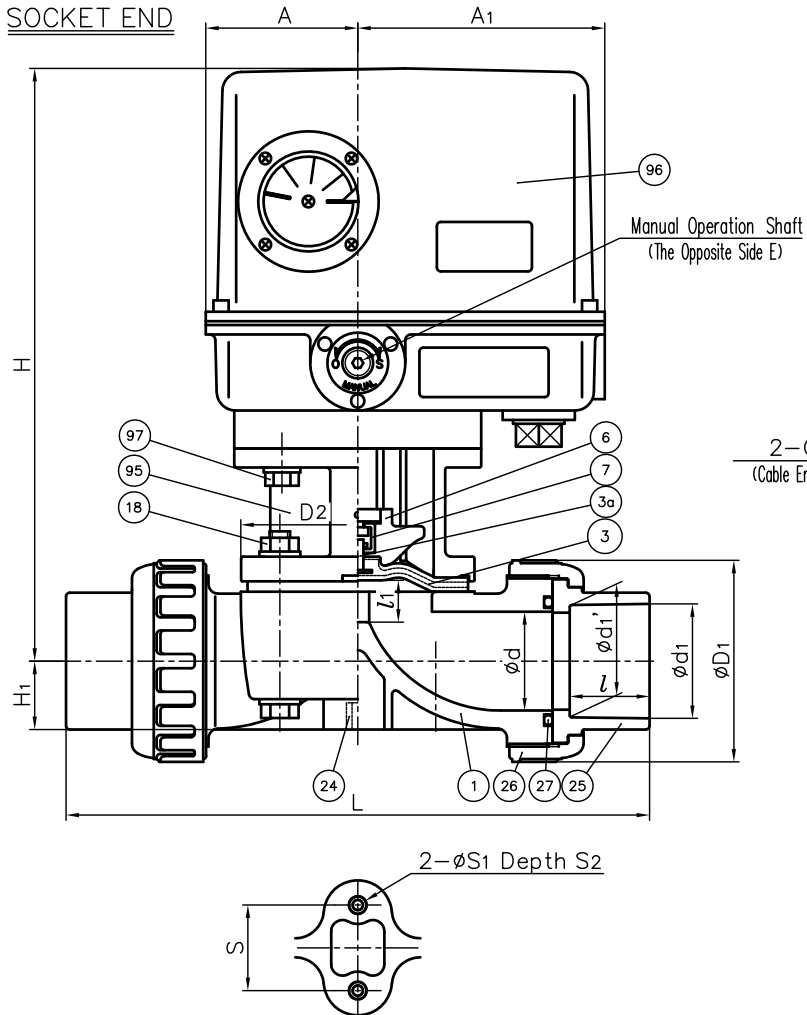

In Case Material of Diaphragm is PTFE

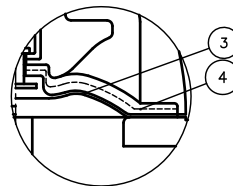

In Case Material of Diaphragm is PTFE with Cushion Cover

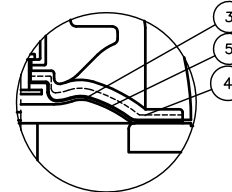

THREADED END

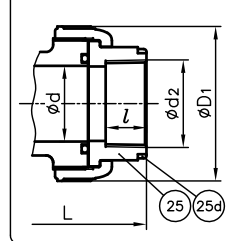

NOTE.

- Diaphragms except EPDM and PTFE are available in FKM, VIFLON[®]C (FKM-C), VIFLON[®]F (FKM-F), CSM and NBR when required.
- The shape and appearance of assembly differ a little with nominal size compared to this drawing.

No.	DESCRIPTION	QTY.	MATERIAL	REMARKS
25d	RING	2	STAINLESS STEEL (SUS304)	Used for C-PVC Body. Threaded End :15~25mm
97	BOLT + WASHER (D)	4sets	STAINLESS STEEL (SUS304)	
96	ACTUATOR	1	CAST ALUMINUM ALLOY (AC2A etc.)	Melamine Baking Coat
95	BONNET	1	CAST ALUMINUM ALLOY (AC4C)	Epoxy Coat
27	O-RING (C)	2	□EPDM □Others ()	
24	ENSAT FOR BODY	2	Copper Alloy (Equal to C3603)	
18	BOLT + NUT (A)	4sets	STAINLESS STEEL (SUS304)	
7	JOINT	1	STAINLESS STEEL (SUS304)	
6	COMPRESSOR	1	PVDF	
5	CUSHION COVER	1	□Nothing □PVDF	Used for PTFE Diaphragm
4	CUSHION	1	EPDM	
3a	INSERTED METAL OF DIAPHRAGM	1	STAINLESS STEEL (SUS304)	
3	DIAPHRAGM	1	□EPDM □PTFE □Others ()	
26	UNION NUT	2	□PVC □C-PVC	
25	END CONNECTOR	2	□PP □PVDF	
1	BODY	1	□PVDF	

ITEM	T.U. DIAPHRAGM VALVE (TYPE14) ELECTRIC MODEL TYPE H ASSY ANSI : □SOCKET END, □THREADED END 15mm (1/2") ~ 50mm (2")		
DRAWN	M.Iwakiri	DATE	SCALE
CHECKED	H.Kawano	AUG.23.2019	
APPROVED	K.Koushou	DRAWING No. T1-AE001AE m	
SPECIAL ORDER No.	ASAHI YUKIZAI CORPORATION		