

DIMENSIONS TABLE

UNIT: mm

NOMINAL SIZE	d	SOCKET END								THREADED END																ACTUATOR MODEL		
		PVC, C-PVC				PP				d2	l	L		D1	D2	L1 (LIFT)	H	H1	A	A1	A2	A3	E	S	S1		S2	
		d1	l	l'	L	d1	d1'	l	L			PVC C-PVC	PP PVDF															
15mm	1/2"	16	22.11	21.23	1/32	134	21.2	20.2	20	134	Rc 1/2	15	128	128	48	54 x 66	10	284	19.5	80	130	84	80	5	25	M5	10	ED-11H
20	3/4	20	26.13	26.57	1/32	156	26.2	25.2	23	154	Rc 3/4	17	148	148	60	54 x 66	10	286	17.5	80	130	84	80	5	25	M5	10	ED-11H
25	1	25	32.16	33.27	1/32	186	33.0	32.0	25	182	Rc 1	20	172	172	70	67 x 80	12	291	18.5	80	130	84	80	5	25	M5	10	ED-11H
32	1 1/4	32	38.19	42.04	1/32	200	-	-	-	-	Rc 1 1/4	22	188	188	82	67 x 80	12	294.5	22.5	80	130	84	80	5	25	M5	10	ED-11H
40	1 1/2	40	48.21	48.11	1/32	271	47.0	46.0	28	253	Rc 1 1/2	25	245	245	100	110 x 110	21	302.2	27.5	80	130	84	80	5	45	M6	14	ED-11H
50	2	52	60.25	60.17	1/32	303	59.0	58.0	28	275	Rc 2	28	281	278	106	128 x 128	25	311.2	36.0	80	130	84	80	5	45	M6	14	ED-11H

NOTE.

- Diaphragms except EPDM and PTFE are available in FKM, VIFLON<sup>®</sup>C (FKM-C), VIFLON<sup>®</sup>F (FKM-F), CSM and NBR when required.
- The shape and appearance of assembly differ a little with nominal size compared to this drawing.

SOCKET END

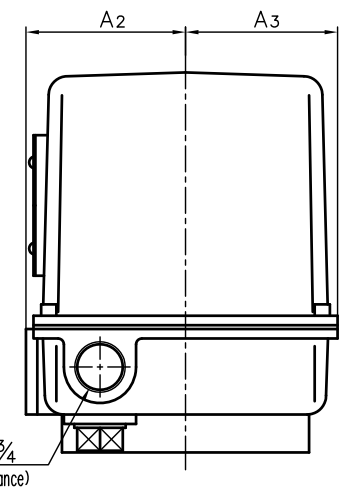
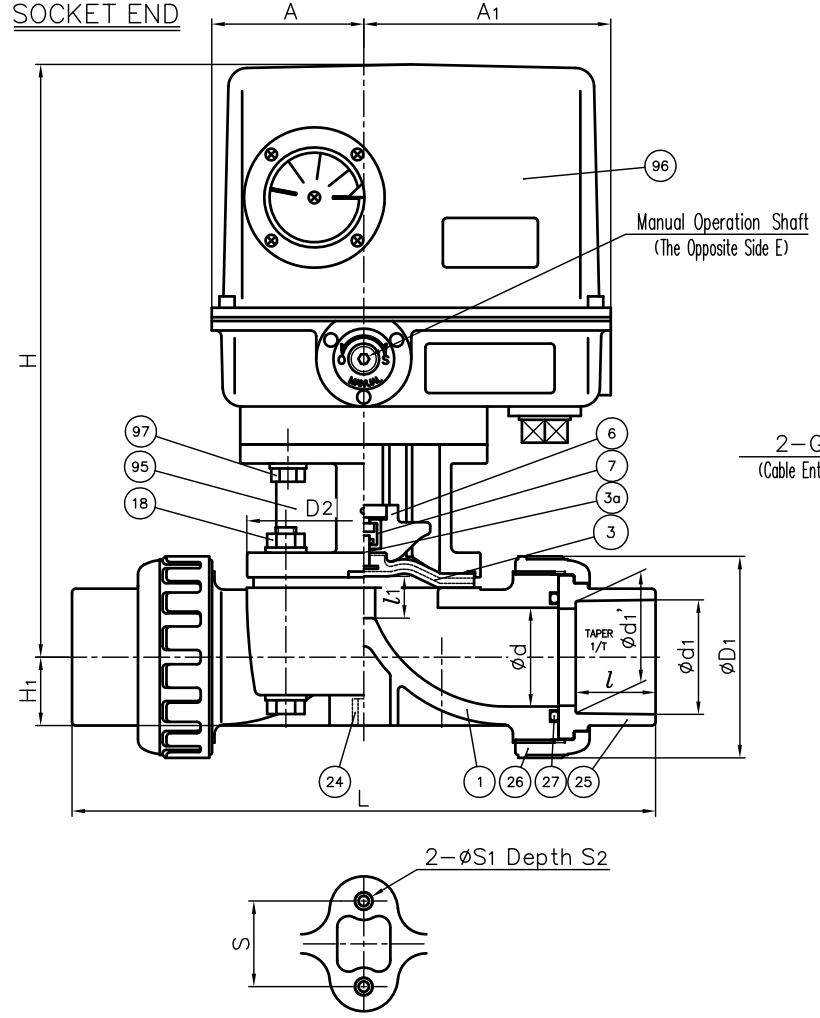

In Case Material of Diaphragm is PTFE

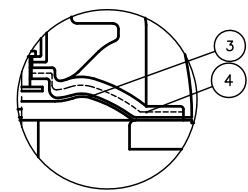

In Case Material of Diaphragm is PTFE with Cushion Cover

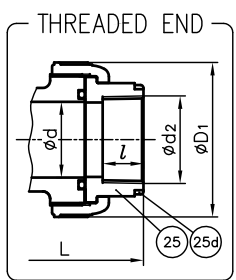
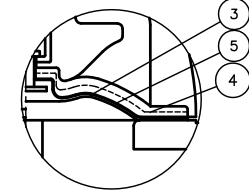

25d	RING	2	STAINLESS STEEL (SUS304)	Used for C-PVC Body. Threaded End :15~25mm
97	BOLT + WASHER (D)	4sets	STAINLESS STEEL (SUS304)	
96	ACTUATOR	1	CAST ALUMINUM ALLOY (AC2A etc.)	Melamine Baking Coat
95	BONNET	1	CAST ALUMINUM ALLOY (AC4C)	Epoxy Coat
27	O-RING (C)	2	□EPDM □Others ( )	
24	ENSAT FOR BODY	2	Copper Alloy (Equal to C3603)	
18	BOLT + NUT (A)	4sets	STAINLESS STEEL (SUS304)	
7	JOINT	1	STAINLESS STEEL (SUS304)	
6	COMPRESSOR	1	PVDF	
5	CUSHION COVER	1	□Nothing □PVDF	Used for PTFE Diaphragm
4	CUSHION	1	EPDM	
3a	INSERTED METAL OF DIAPHRAGM	1	STAINLESS STEEL (SUS304)	
3	DIAPHRAGM	1	□EPDM □PTFE □Others ( )	
26	UNION NUT	2	□PVC □C-PVC	
25	END CONNECTOR	2	□PP □PVDF	
1	BODY	1	□PVDF	
No.	DESCRIPTION	QTY.	MATERIAL	REMARKS
ITEM	T.U. DIAPHRAGM VALVE (TYPE14) ELECTRIC MODEL TYPE H ASSY JIS : □SOCKET END, □THREADED END 15mm (1/2") ~ 50mm (2")			
DRAWN	M.Iwakiri	DATE	SCALE	
CHECKED	H.Kawano	AUG.23.2019		
APPROVED	K.Koushou	DRAWING No.		
		T1-AE001JE		3
SPECIAL ORDER No.	ASAHI YUKIZAI CORPORATION			