

DIMENSIONS TABLE

UNIT:mm

NOMINAL SIZE	SOCKET END								THREADED END				SPIGOT END								ACTUATOR MODEL											
	PVC,C-PVC				PP,PVDF				L	PVC C-PVC	PP PVDF	PVC				PP,PVDF																
	d	d1	l	L	d1	d1'	l	L				d2	l	d3	l	L	d3	l	PP	PVDF		L										
15mm 1/2"	16	20	16	128	19.5	19.3	14.5	125	Rp 1/2	15	128	128	20	18.5	150	20	18.5	2.5	1.9	150	48	54 × 66	10	406	19.5	101	81	140	25	M5	10	PSN-1
20 3/4"	20	25	19	147	24.5	24.3	16	141	Rp 3/4	17	148	148	25	24	172	25	22	2.7	1.9	172	60	54 × 66	10	408	17.5	101	81	140	25	M5	10	PSN-1
25 1"	25	32	22	172	31.5	31.3	18	164	Rp 1	20	172	172	32	24.5	195	32	22.5	3.0	2.4	195	70	67 × 80	12	413	18.5	101	81	140	25	M5	10	PSN-1
32 1 1/4"	32	40	26	188	39.45	39.2	20.5	177	Rp 1 1/4	22	188	188	40	28	212	40	26	3.7	2.4	212	82	67 × 80	12	416	22.5	101	81	140	25	M5	10	PSN-1
40 1 1/2"	40	50	31	246	49.45	49.2	23.5	231	Rp 1 1/2	25	245	245	50	34	276	50	32	4.6	3.0	276	100	110 × 110	21	464	27.5	110	90	150	45	M6	14	PSN-3
50 2"	52	63	38	294	62.5	62.1	27.5	274	Rp 2	28	281	278	63	38.5	308	63	36	5.8	3.0	307	106	123 × 123	25	473	36.0	110	90	150	45	M6	14	PSN-3

SOCKET END

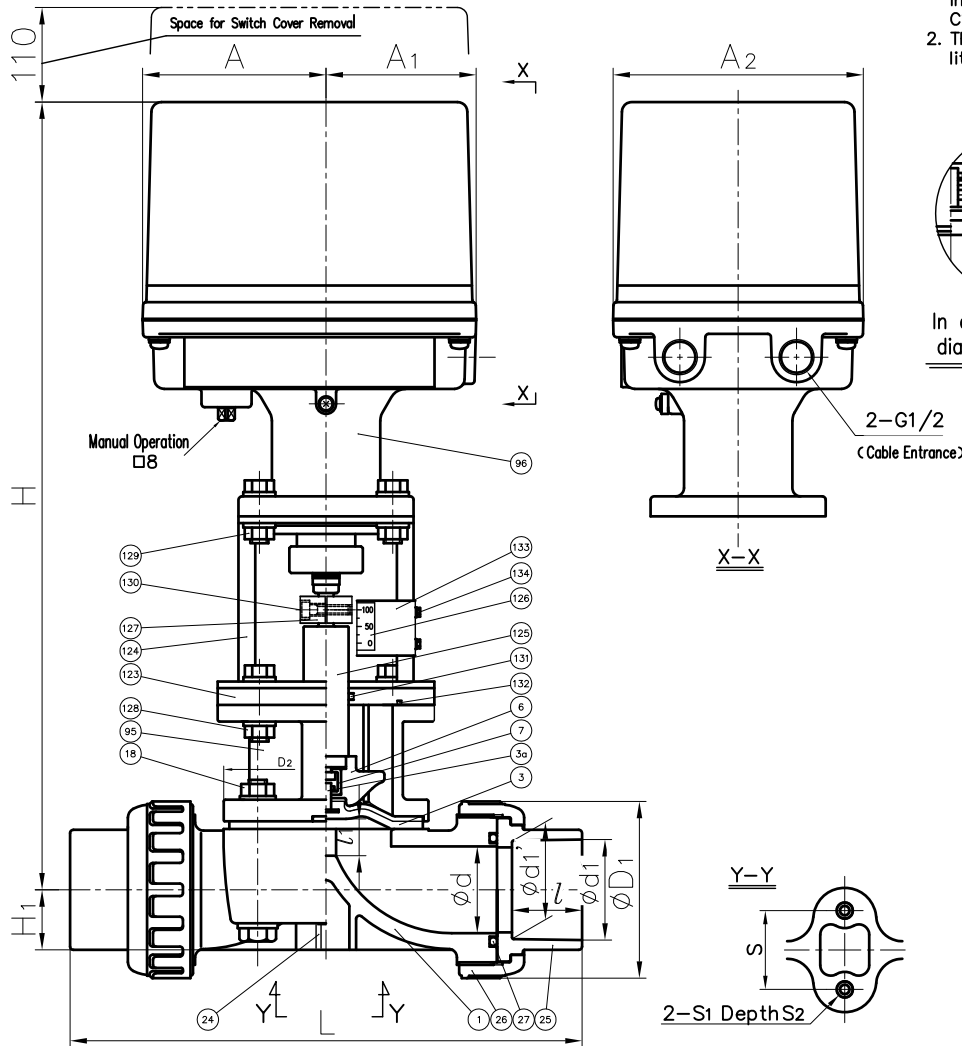

NOTE.

- Diaphragms except EPDM and PTFE are available in FKM, VIFLON[®] C (FKM-C), VIFLON[®] F (FKM-F), CSM and NBR when required.
- The shape and appearance of assembly differ a little with nominal size compared to this drawing.

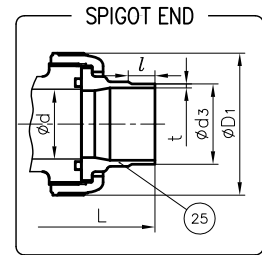
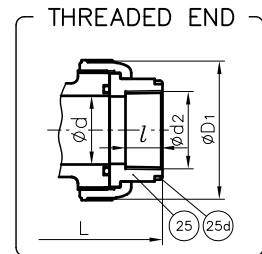
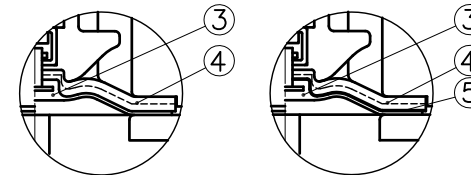

25d	RING	2	STAINLESS STEEL (SUS304)	Used for C-PVC Body, Threaded End :15~22"
134	SCREW (F)	2	STAINLESS STEEL (SUS304)	
133	INDICATOR PLATE	1	STAINLESS STEEL (SUS304)	
132	O-RING (K)	1	NBR	
131	O-RING (J)	1	NBR	
130	BOLT (F)	2	STAINLESS STEEL (SUS304)	
129	BOLTO · NUT (F)	4Sets	STAINLESS STEEL (SUS304)	
128	BOLTO · NUT (E)	4Sets	STAINLESS STEEL (SUS304)	
127	JOINT	1	COPPER ALLOY (C3604)	
126	INDICATOR SEAL	1	ACRYL	
125	STEM (D)	1	COPPER ALLOY (C3604)	
124	STAND (A)	1	STAINLESS STEEL (SUS304)	
123	SPACER (A)	1	PVC	
96	ACTUATOR	1	ALUMINIUM etc.	Acryl Coat
95	BONNET	1	CAST ALUMINIUM ALLOY (AC4A)	Epoxy Coat
27	O-RING (C)	2	□EPDM □Others ()	
24	ENSAT FOR BODY	2	COPPER ALLOY (Equal to C3603)	
18	BOLT · NUT (A)	4Sets	STAINLESS STEEL (SUS304)	
7	JOINT	1	STAINLESS STEEL (SUS304)	
6	COMPRESSOR	1	PVDF	
5	CUSHION COVER	1	□Noting □PVDF	Used for PTFE Diaphragm
4	CUSHION	1	EPDM	
3a	INSERTED METAL OF DIAPHRAGM	1	STAINLESS STEEL (SUS304)	
3	DIAPHRAGM	1	□EPDM □PTFE □Others ()	
26	UNION NUT	2	□PVC □C-PVC	
25	END CONNECTOR	1	□PP □PVDF	
1	BODY	1	□PVDF	
No.	DESCRIPTION	QTY.	MATERIAL	REMARKS

ITEM	T.U. DIAPHRAGM VALVE (TYPE14) ELECTRIC MODEL TYPE M ASS'Y DIN : □SOCKET END, □THREADED END 15mm (1/2") ~ 50mm (2") with E-P POSITIONER		
DRAWN	M. Iwakiri	DATE	SCALE
CHECKED	H. Kawano	AUG. 15, 2019	~
APPROVED	K. Kaushou	DRAWING No. T1-AE002DE	
SPECIAL ORDER No.	ASAHI YUKIZAI CORPORATION		