

DIMENSIONS TABLE

Unit: inch

Nominal Size	FLANGE END																		SOCKET END												THREADED END										ACTUATOR TYPE
	ANSI Class 150						PVC, C-PVC						PP,PVDF																												
	d	d'	D	C	n	h	L	t	H1	d1	d1'	L	L	H1	d1	L	L	H1	d2	L	L	H1	D1	H	A	A2	A3	P													
1/2"	15mm	0.59	0.59	3.50	2.38	4	0.62	5.63	0.47	3.70	0.848	0.836	0.875	4.45	3.08	0.83	0.87	4.45	3.09	1/2 - 14 NPT	0.59	4.02	2.89	1.89	5.16	4.57	1.10	1.50	1/8	ARO40DA20CN											
3/4"	20	0.79	0.79	3.88	2.75	4	0.62	6.77	0.55	4.50	1.058	1.046	1.000	5.08	3.56	1.03	1.00	5.08	3.61	3/4 - 14 NPT	0.67	4.72	3.48	2.36	5.41	4.57	1.10	1.50	1/8	ARO40DA20CN											
1"	25	0.98	0.98	4.25	3.12	4	0.62	7.36	0.55	5.24	1.325	1.310	1.125	5.75	4.32	1.30	1.13	5.75	4.37	1 - 11 1/2 NPT	0.79	5.16	4.13	2.76	5.69	4.57	1.10	1.50	1/8	ARO40DA20CN											
1 1/4"	32	1.57	1.26	4.62	3.50	4	0.62	8.35	0.63	6.50	1.670	1.655	1.250	6.85	5.51	1.65	1.25	7.04	5.75	1 1/4 - 11 1/2 NPT	0.87	6.42	5.53	3.94	6.87	5.79	1.38	1.93	1/4	ARO50DA30NN											
1 1/2"	40	1.57	1.26	5.00	3.88	4	0.62	8.35	0.63	6.50	1.912	1.894	1.375	7.24	5.71	1.89	1.37	7.24	5.85	1 1/2 - 11 1/2 NPT	0.98	6.42	5.53	3.94	6.87	5.79	1.38	1.93	1/4	ARO50DA30NN											
2"	50	2.01	1.69	6.00	4.75	4	0.75	9.21	0.63	7.34	2.387	2.369	1.500	8.23	6.66	2.36	1.50	8.23	6.76	2 - 11 1/2 NPT	1.10	7.76	6.61	4.96	7.32	5.79	1.38	1.93	1/4	ARO50DA30NN											

NOTE.

- Operating Pressure: 0.4~0.7MPa G
- Port I ↔ II: Port (a) supply Port (b) exhaust
Port II ↔ I: Port (a) exhaust Port (b) supply
- The shape and appearance of assembly differ a little with nominal size compared to this drawing.

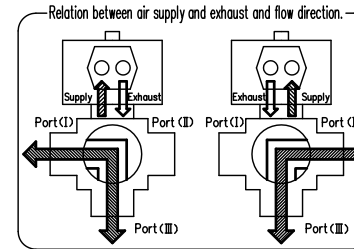

FLANGE END

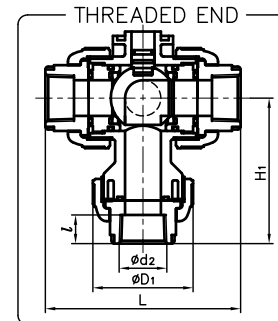
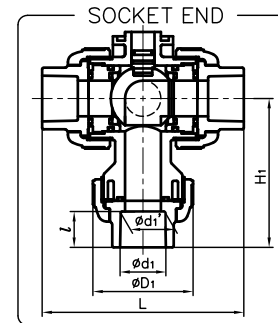
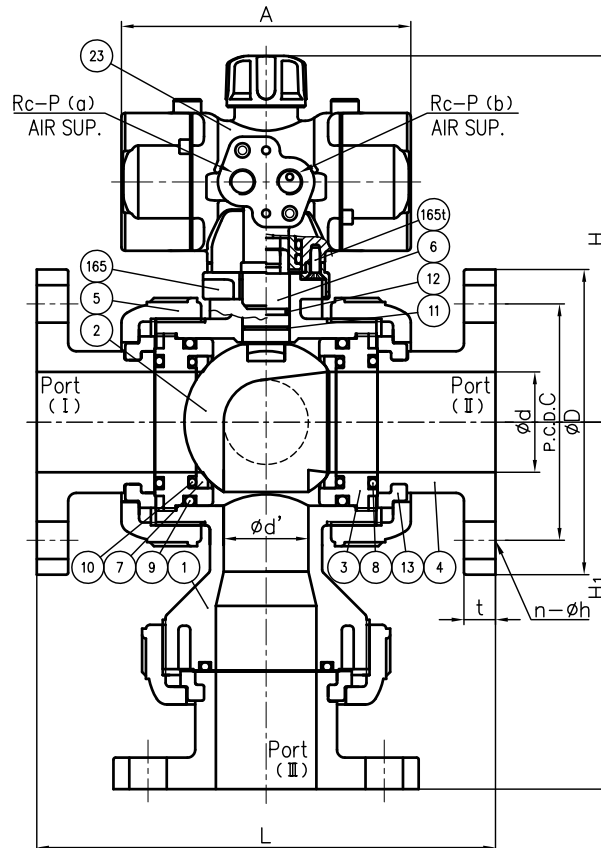
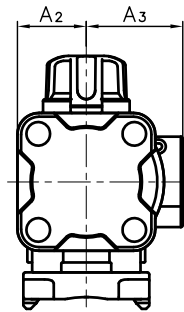

Actuator Shape (AR040)

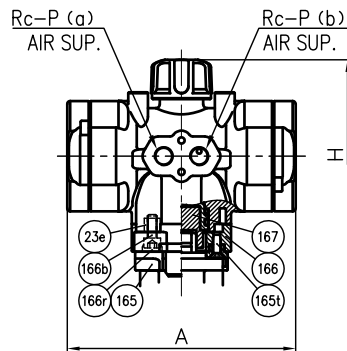

4a	RING	3	STAINLESS STEEL (SUS304)	Used for C-PVC Body, Threaded End: 1/2"~1"
167	SHAFT ADAPTER	1	COPPER ALLOY (C3604)	Used for Actuator Type ARO40
166r	CAP (No.166)	4	EPDM	
166b	BOLT (No.166)	4	STAINLESS STEEL (SUS304)	
166	CONNECTOR PLATE	1	PPG	
165t	TAPPING SCREW (No.165)	2	STAINLESS STEEL (SUS304)	
165	BASE PLATE	1	PPG	
23e	ENSAT (No.23)	4	COPPER ALLOY (C3604)	Used for Actuator Type ARO40
23	ACTUATOR	1	PPG etc.	
13	STOP RING	3	PVDF	Used for Flanged End
12	O-RING (E)	1		
11	O-RING (D)	1	□EPDM	
10	O-RING (C)	2	□FKM	
9	O-RING (B)	2	□Others	
8	O-RING (A)	3	()	
7	SEAT	2	PTFE	
6	STEM	1		
5	UNION NUT	3	□PVC	
4	END CONNECTOR	3	□C-PVC	
3	CARRIER	2	□PP	
2	BALL	1	□PVDF	
1	BODY	1		
No.	DESCRIPTION	QTY.	MATERIAL	REMARKS

ITEM	3-WAY BALL VALVE (TYPE 23) PNEUMATIC MODEL AR TYPE ASSY DOUBLE ACTING: DOUBLE L-PORT TYPE ANSI: □ FLANGED END, □ SOCKET END, □ THREADED END 1/2" (15mm) ~ 2" (50mm)			
DRAWN	E.Ozaki	DATE	SCALE	
CHECKED	H.Kawano	APR.23.2018	DRAWING No.	
APPROVED	K.Kousyou	T3-AA058AE	▲	
SPECIAL ORDER No.	ASAHI YUKIZAI CORPORATION			