

Rotary Damper (Manual Type)

Features

-Butterfly valve for air volume control (complete sealing is not available.)



Basic specifications

- Valve Type	:	Rotary Damper
- Size	:	40 mm - 600 mm (1 1/2 inch - 24 inch)
- Body Material	:	U-PVC (Conforming to ASTM D1784 Cell Classification 12454A) PP (Conforming to ASTM D4101 Cell Classification PP0210B67272) PVDF (Conforming to ASTM D3222 Cell Classification Type II)
- Seal Material	/ O-ring	: EPDM, FKM, etc.
- Connection	/ Wafer	: JIS B2220 10K, JIS B2220 5K, DIN/EN1092-1 PN10, ANSI B16.5 CLASS150

	FLUID TEMPERATURE °C {°F}	MAXIMUM WORKING PRESSURE (NORMAL TEMPERATURE) MPa {psi}	
		40mm - 200mm	250mm - 600mm
U-PVC	0 ~ 50 { 30~120 }	0.1 { 15 }	0.05 { 7 }
PP	-20 ~ 80 { -5~175 }	0.1 { 15 }	0.05 { 7 }
PVDF	-20 ~ 120 { -5~250 }	0.1 { 15 }	0.05 { 7 }

Note: The maximum working pressure is the value including the water hammer pressure.
Be careful that the maximum working pressure is not exceeded during use.

* Concerning the allowable pressure for each temperature and material, see the technical documents at the next page of this sheet.

Certificate / Approval

PED

“For details of applicable products, please consult us.”

Working pressure vs. Temperature

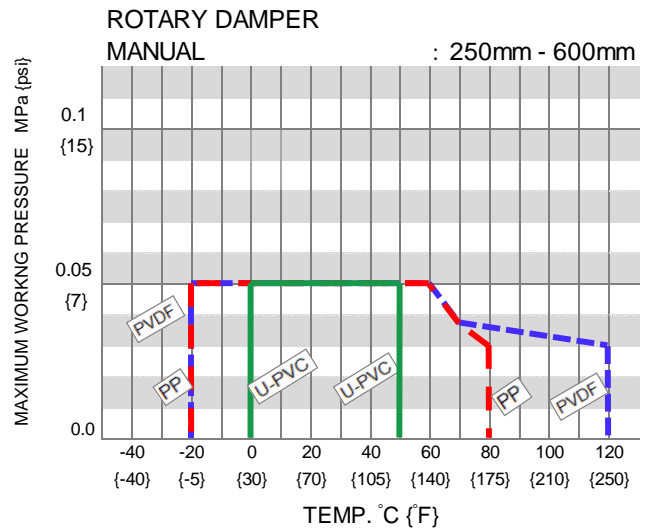
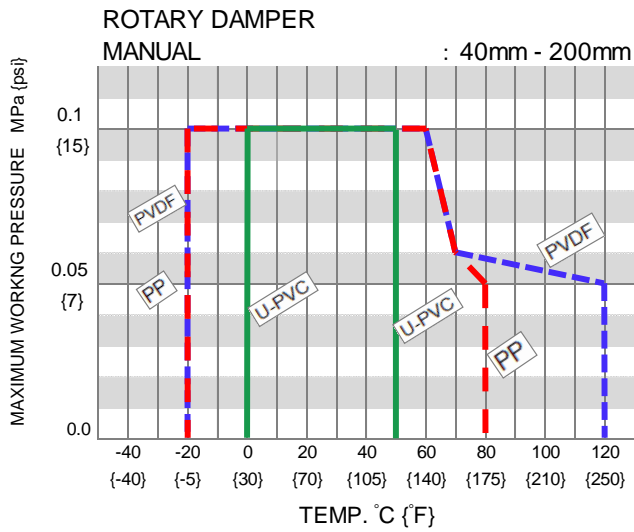

Note: Make sure that the temperature and pressure are within the working range during operation.
(If the tolerance range is exceeded during use, the valve may be damaged.)

Product dimension

40mm (1 1/2") - 200mm (8")

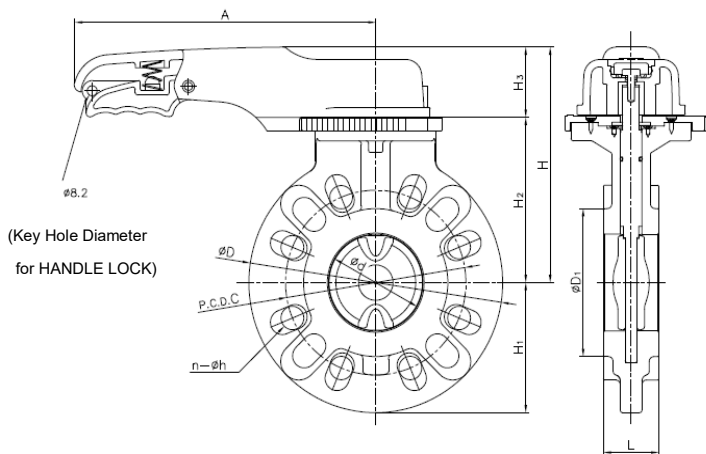

250mm (10") - 350mm (14")

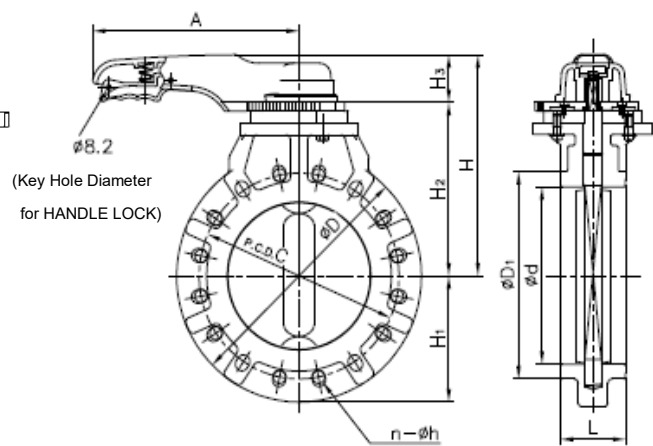

400mm (16")

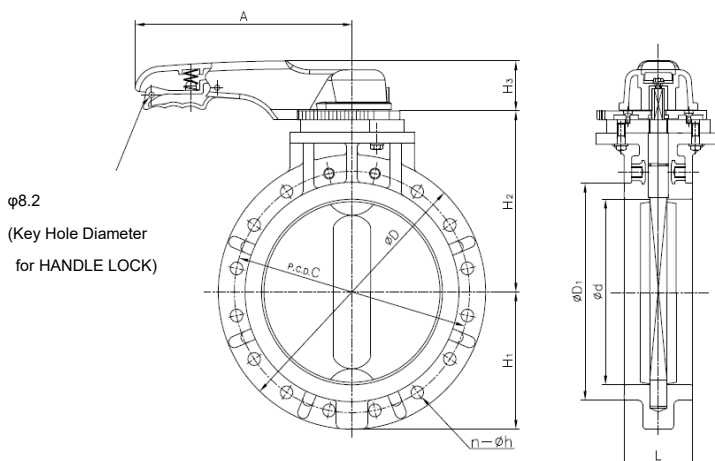

Detail of inserted nuts

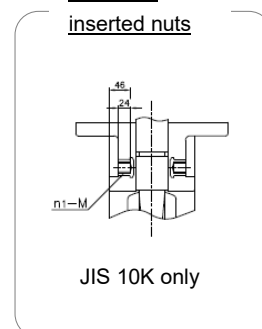

PP 450mm (18") - 600mm (24")

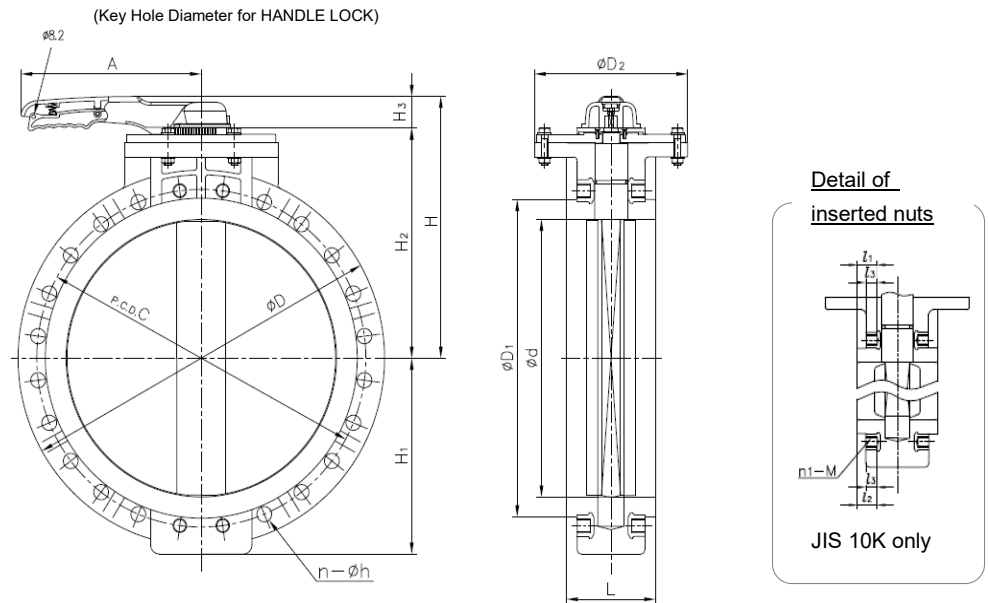

PVDF

450mm (18") - 600mm (24")

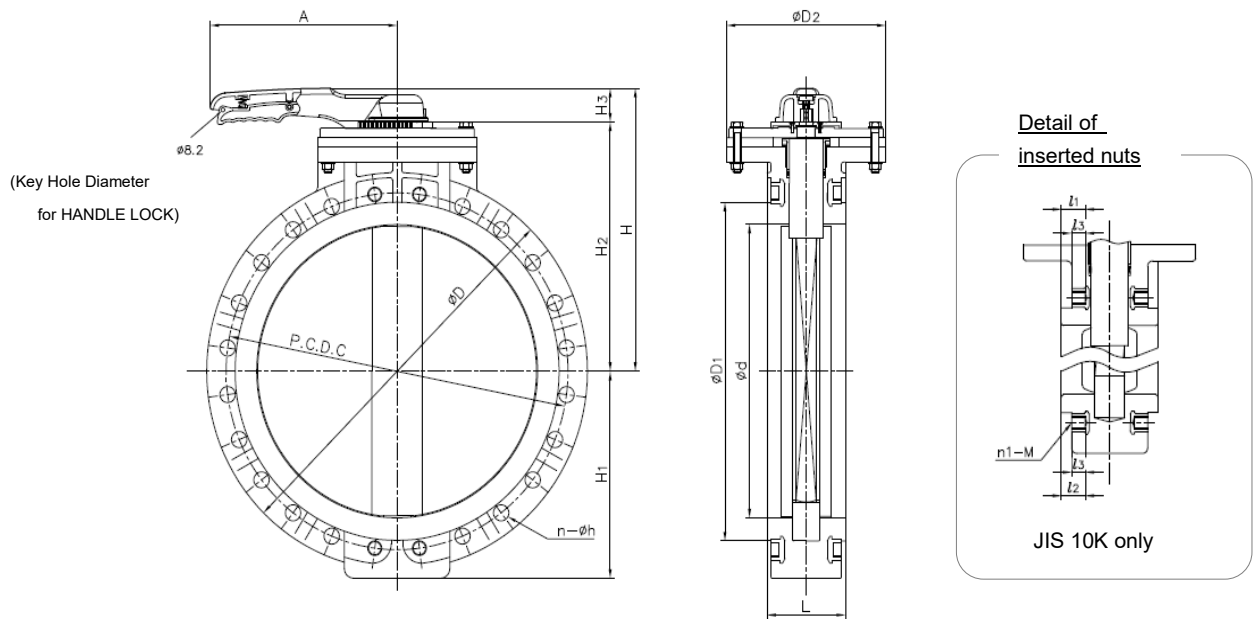

BODY: U-PVC, PP

■ 40 - 600mm JIS, DIN (Unit: mm)

mm	inch	d	D	D ₁	L	H	H ₁	H ₂	H ₃	A	JIS 5K			JIS 10K					DIN PN10		
											C	n	h	C	n	h	n1	M	C	n	h
40	1 1/2	46	150	86	32	156	75	100	56	220	95	4	15	105	4	19	-	-	110	4	18
50	2	57	165	96	35	166	83	110	56	220	105	4	15	120	4	19	-	-	125	4	18
65	2 1/2	70	185	116	37	176	93	120	56	220	130	4	15	140	4	19	-	-	145	4	18
80	3	78	211	120	37	191	106	135	56	250	145	4	19	150	8	19	-	-	160	8	18
100	4	103	238	152	47	206	119	150	56	250	165	8	19	175	8	19	-	-	180	8	18
125	5	128	263	190	57	237	132	168	69	320	200	8	19	210	8	23	-	-	210	8	18
150	6	150	285	208	62	252	143	183	69	320	230	8	19	240	8	23	-	-	240	8	22
200	8	195	340	264	76	283	170	214	69	400	280	8	23	290	12	23	-	-	295	8	22
250	10	251	421	332	96	342	211	273	69	400	345	12	23	355	12	25	-	-	350	12	23
300	12	303	488	400	116	399	244	330	69	400	390	12	23	400	16	25	-	-	400	12	23
350	14	352	539	414	116	426	270	357	69	400	435	12	25	445	16	25	-	-	460	16	23
400	16	394	600	470	157	451	300	382	69	400	495	16	25	510	14	27	2	M24	515	16	27
450	18	441	630	525	167	496	315	402	69	400	555	16	25	565	16	27	4	M24	565	20	27
500	20	488	699	575	177	526	350	432	69	400	605	20	25	620	16	27	4	M24	620	20	27
600	24	600	813	686	197	591	424	497	69	400	715	20	27	730	20	33	4	M30	725	20	30

DATASHEET

BODY: PVDF

■ 450 - 600mm JIS, DIN (Unit: mm)

mm	inch	d	D	D ₁	L	H	H ₁	H ₂	H ₃	A	JIS 5K			JIS 10K					DIN PN10		
											C	n	h	C	n	h	n1	M	C	n	h
450	18	441	630	525	167	491	315	422	69	400	555	16	25	565	16	27	4	M24	565	20	27
500	20	488	680	575	177	521	350	452	69	400	605	20	25	620	16	27	4	M24	620	20	27
600	24	600	790	686	197	586	424	517	69	400	715	20	27	730	20	33	4	M30	725	20	30

BODY MATERIAL U-PVC,PP

■ 40 - 600mm ANISI (Unit: inch)

inch	mm	d	D	D ₁	L	H	H ₁	H ₂	H ₃	A	ANSI CLASS 150		
											C	n	h
1 1/2	40	1.81	5.91	3.39	1.26	6.14	2.95	3.94	2.20	8.66	3.88	4	0.62
2	50	2.24	6.50	3.78	1.38	6.54	3.27	4.33	2.20	8.66	4.75	4	0.75
2 1/2	65	2.76	7.28	4.57	1.46	6.93	3.66	4.72	2.20	8.66	5.50	4	0.75
3	80	3.07	8.31	4.72	1.46	7.52	4.17	5.31	2.20	9.84	6.00	4	0.75
4	100	4.06	9.37	5.98	1.85	8.11	4.69	5.91	2.00	9.81	7.50	8	0.75
5	125	5.08	10.35	7.48	2.24	9.33	5.20	6.61	2.72	12.60	8.50	8	0.88
6	150	5.91	11.22	8.19	2.44	9.92	5.63	7.20	2.72	12.60	9.50	8	0.88
8	200	7.68	13.39	9.53	2.99	11.14	6.69	8.43	2.72	15.75	11.75	8	0.88
10	250	9.88	16.57	13.07	3.78	13.46	8.31	10.75	2.72	15.75	14.25	12	1.00
12	300	11.93	19.21	15.75	4.57	15.71	9.61	12.99	2.72	15.75	17.00	12	1.00
14	350	13.86	21.22	16.30	4.57	16.77	10.63	14.06	2.72	15.75	18.74	12	1.12
16	400	15.51	23.62	18.50	6.18	17.76	11.81	15.04	2.72	15.75	21.25	16	1.12
18	450	17.36	24.92	20.67	6.57	19.53	12.40	15.83	2.72	15.75	22.75	16	1.25
20	500	19.21	27.52	22.64	6.97	20.71	13.78	17.01	2.72	15.75	25.00	20	1.25
24	600	23.62	32.01	27.01	7.76	23.27	16.69	19.57	2.72	15.75	29.50	20	1.38

BODY MATERIAL PVDF

■ 40 - 600mm ANISI (Unit: inch)

inch	mm	d	D	D ₁	L	H	H ₁	H ₂	H ₃	A	ANSI CLASS 150		
											C	n	h
1 1/2	40	1.81	5.91	3.39	1.26	7.05	2.95	4.84	2.20	8.66	3.88	4	0.62
2	50	2.24	6.5	3.78	1.38	7.44	3.27	5.24	2.20	8.66	4.75	4	0.75
2 1/2	65	2.76	7.28	4.57	1.46	7.83	3.66	5.63	2.20	8.66	5.50	4	0.75
3	80	3.07	8.31	4.72	1.46	8.43	4.17	6.22	2.20	9.84	6.00	4	0.75
4	100	4.06	9.37	5.98	1.85	9.02	4.69	6.81	2.00	9.81	7.50	8	0.75
5	125	5.08	10.35	7.48	2.24	10.12	5.20	7.40	2.72	12.60	8.50	8	0.88
6	150	5.91	11.22	8.19	2.44	10.71	5.63	7.99	2.72	12.60	9.50	8	0.88
8	200	7.68	13.39	9.53	2.99	11.93	6.69	9.21	2.72	15.75	11.75	8	0.88
10	250	9.88	16.57	13.07	3.78	13.62	8.31	10.91	2.72	15.75	14.25	12	1.00
12	300	11.93	19.21	15.75	4.57	16.50	9.61	13.78	2.72	15.75	17.00	12	1.00
14	350	13.86	21.22	16.3	4.57	17.56	10.63	14.84	2.72	15.75	18.74	12	1.12
16	400	15.51	23.62	18.5	6.18	18.54	11.81	15.83	2.72	15.75	21.25	16	1.12
18	450	17.36	24.92	20.67	6.57	19.33	12.40	16.61	2.72	15.75	22.75	16	1.25
20	500	19.21	27.52	22.64	6.97	20.51	13.78	17.80	2.72	15.75	25.00	20	1.25
24	600	23.62	32.01	27.01	7.76	23.07	16.69	20.35	2.72	15.75	29.50	20	1.38

(Detail of inserted nuts)

BODY: PP

(Unit: mm)

mm	inch	l_1	l_2	l_3
450	18	43	48	24
500	20	43	53	24
600	24	58	58	30

BODY: PVDF

(Unit: mm)

mm	inch	l_1	l_2	l_3
450	18	49	54	24
500	20	49	59	24
600	24	64	64	30

The shape and appearance of assembly differ a little with nominal size compared to this drawing.

Parts list

40mm (1 1/2") - 200mm (8")

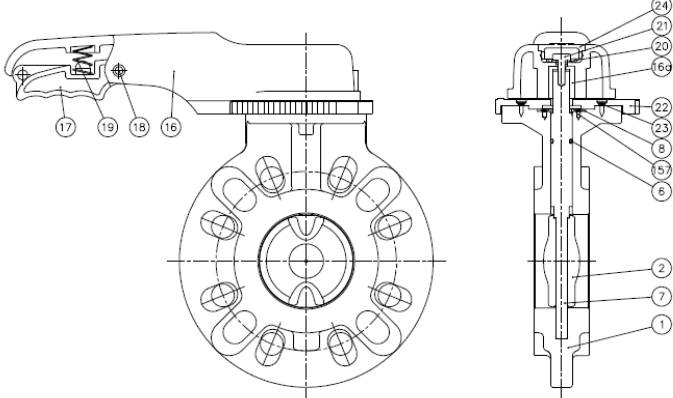

250mm (10") - 350mm (14")

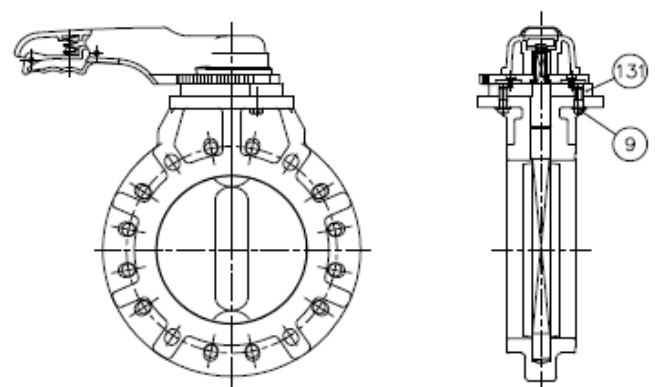

400mm (1 6")

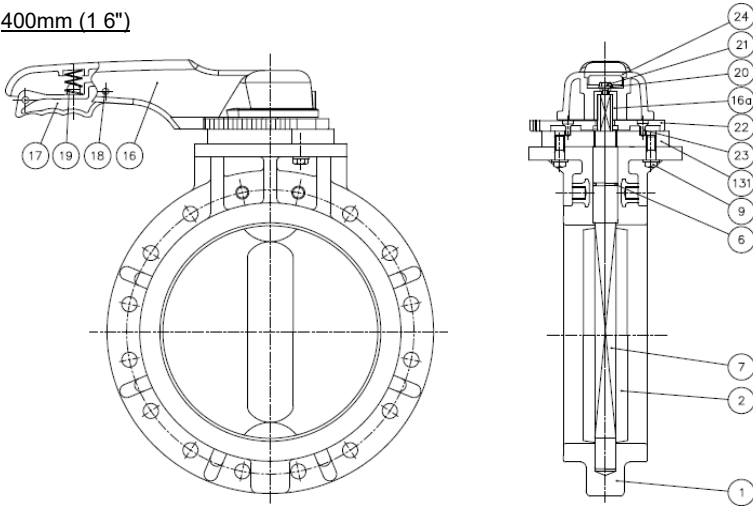

Detail of inserted nuts

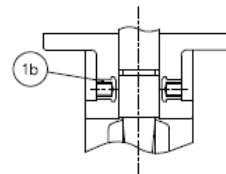

JIS 10K only

PP 450mm (18") - 600mm (24")

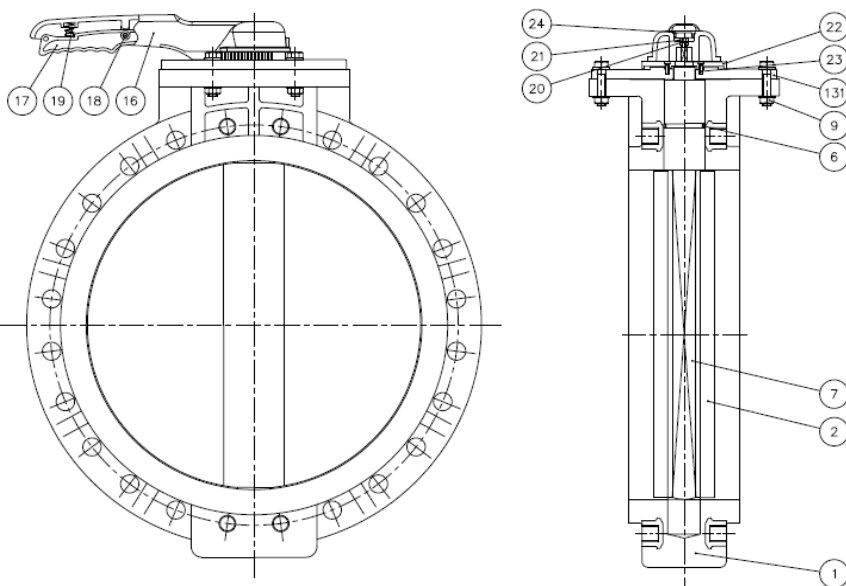

Detail of inserted nuts

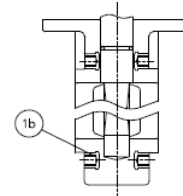

JIS 10K only

DATASHEET

PVDF 450mm (18") - 600mm (24")

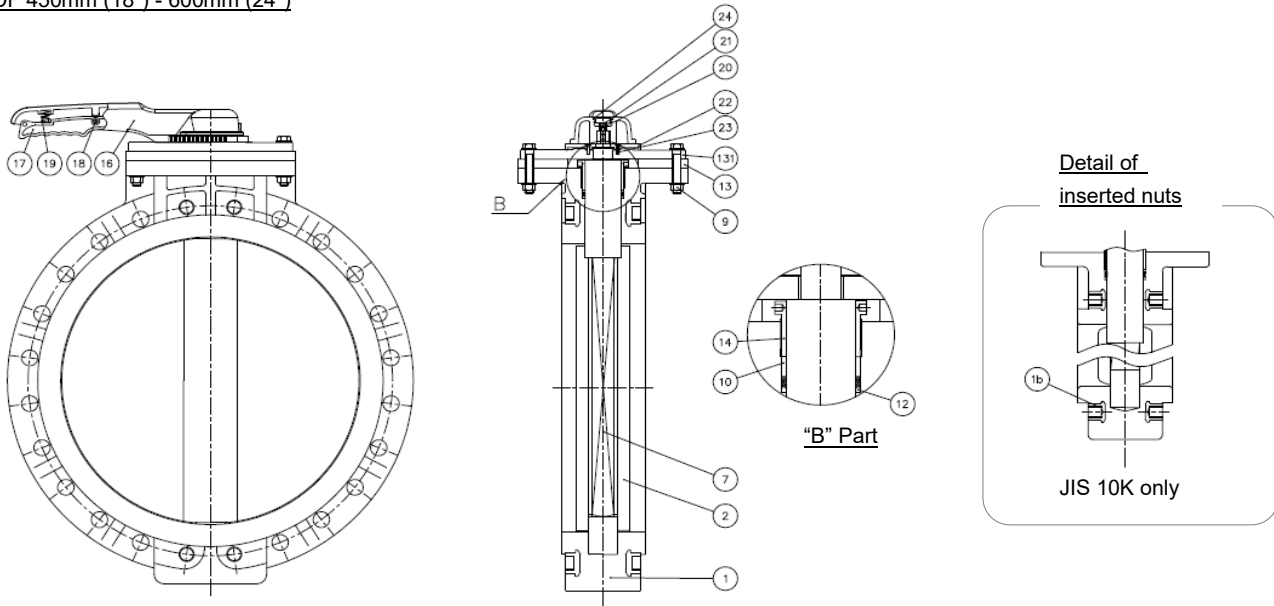

■ 40 - 350mm JIS, DIN, ANSI

PART NO./NAME	QTY	MATERIAL	PART NO./NAME	QTY	MATERIAL	PART NO./NAME	QTY	MATERIAL
1 BODY	1	BODY / STEM PVC / PVC	17 HANDLE LEVER	1	PPG	24 CAP (A)	1	PP
7 STEM	1	PP / PP	18 PIN	1	PPG	157 SCREW (F)	4	STAINLESS STEEL Used for Size 40-200mm
2 DISC	1	PP	19 SPRING	1	STAINLESS STEEL	9 BOLT (A)	3	STAINLESS STEEL Used for Size 250-350mm
6 O-RING (C)	1	EPDM, FKM, Others	20 WASHER (A)	1	STAINLESS STEEL	131 STEM HOLDER (C)	1	PP Used for Size 250-350mm
8 STEM HOLDER (A)	1	PP	21 BLOT (B)	1	STAINLESS STEEL			
16 HANDLE (A)	1	PP	22 LOCKING PLATE	1	PPG			
16a HANDLE INSERTED METAL	1	STAINLESS STEEL	23 SCREW (B)	4	STAINLESS STEEL			

■ 400 - 600mm JIS, DIN, ANSI

PART NO./NAME	QTY	MATERIAL	PART NO./NAME	QTY	MATERIAL	PART NO./NAME	QTY	MATERIAL
1 BODY	1	PP, PVDF	21 BOLT (B)	1	STAINLESS STEEL	12 V-PACKING	1Set	PTFE Used for PVDF Body
2 DISC	1	PP, PVDF	22 LOCKING PLATE	1	PPG	13 SPACER (A)	1Set	C-PVC Used for PVDF Body
7 STEM	1	PP, PVDF	23 SCREW (B)	4	STAINLESS STEEL	14 GLAND	1	PVDF Used for PVDF Body
9 BOLT&NUT(A)	3Set	STAINLESS STEEL	24 CAP (A)	1	PP	1b INSERTED METAL OF BODY	8	COPPER ALLOY Used for JIS 10K
16 HANDLE (A)	1	PP	131 STEM HOLDER (C)	1	PP			
17 HANDLE LEVER	1	PPG	6 O-RING (C)	1	EPDM, FKM, Others Used for PP Body			
18 PIN	1	PPG	10 BUSH (A)	1	PVDF Used for PVDF Body			
19 SPRING	1	STAINLESS STEEL						
20 WASHER (A)	1	STAINLESS STEEL						

Cv value for each opening degree

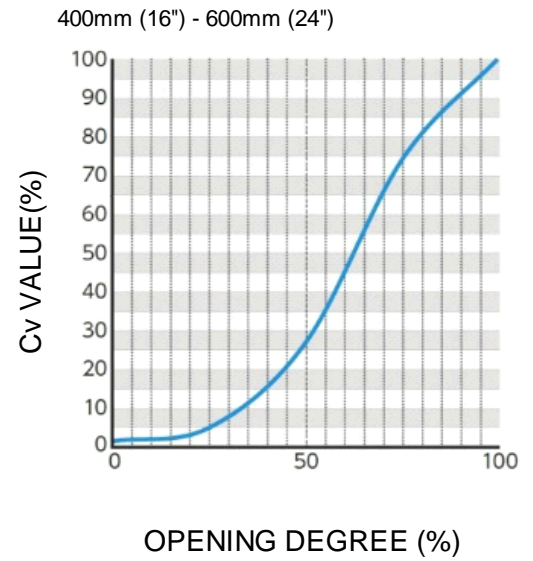
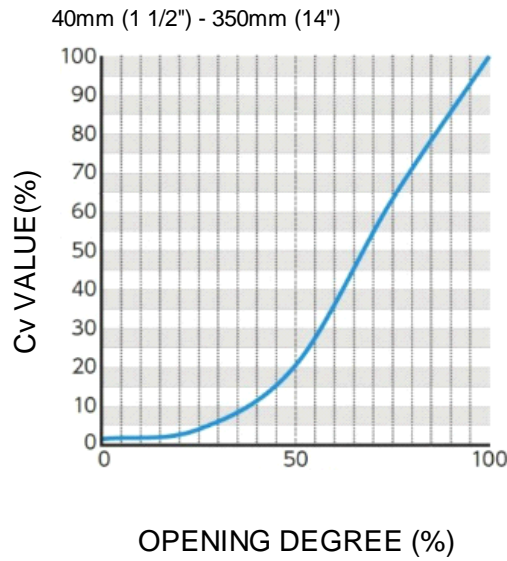

mm	40	50	65	80	100	125	150	200	250	300	350	400	450	500	600
inch	1 1/2	2	2 1/2	3	4	5	6	8	10	12	14	16	18	20	24
ROTARY DAMPER	71	120	250	300	470	830	1,100	2,500	3,860	5,700	6,440	8,340	10,890	14,060	18,500

The values shown are reference values, not guaranteed values.

Operating torque

UNIT : N · m

mm	40	50	65	80	100	125	150	200	250	300	350	400	450	500	600
inch	1 1/2	2	2 1/2	3	4	5	6	8	10	12	14	16	18	20	24
Operation torque (O→S)	5	10	15	20	30	40	65	165	300	330	400	760	820	1,150	1,600

The values shown are reference values, not guaranteed values.

Dimension of bolt length (reference:recommended data)

BOLT A

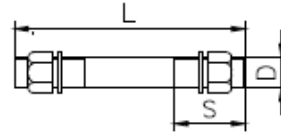

BOLT B

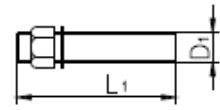

■ JIS 10K

UNIT : mm

mm	inch	BOLT A			BOLT B				QTY		
		d	L	S	d ₁	L ₁	S ₁	S ₂	BOLT A	BOLT B	NUT / WASHER
40	1 1/2	M16	115	40	—	—	—	—	4	—	8
50	2		125	45							
65	2 1/2		135								
80	3		135								
100	4		145								
125	5	M20	165	55	—	—	—	8	—	16	
150	6		175								
200	8		195								
250	10	M22	225	60	—	—	—	12	—	24	
300	12		245								
350	14		255								65
400	16	M24	290	60	M24	115	60	30	14	4	32
450	18		305	65		120	65		16	8	40
500	20		315	—		—	—		—	—	—
600	24	M30	350	75	M30	135	70	40	20	—	48

■ JIS 5K

UNIT : mm

mm	inch	BOLT A			BOLT B				QTY		
		d	L	S	d ₁	L ₁	S ₁	S ₂	BOLT A	BOLT B	NUT / WASHER
40	1 1/2	M12	100	30	—	—	—	—	4	—	8
50	2		105	35							
65	2 1/2		110								
80	3	M16	120	40	—	—	—	—	8	—	16
100	4		130								
125	5		140								
150	6		150								
200	8	M20	195	55	—	—	—	—	12	—	24
250	10		225	60							
300	12		240								
350	14		255								
400	16	M22	260	55	—	—	—	—	16	—	32
450	18		270								
500	20		280								
600	24	M24	315	60	—	—	—	—	20	—	40

In the above list, the values for size 40 to 350 mm indicate the bolt dimensions when an AVTS flange is used.

The values for size 400 to 600 mm indicate the bolt dimensions when a JIS B2238 "steel pipe flange" (nominal pressure 10K, corrugated) is used.

The quantity of nuts and washers for Bolt A indicates the number of 2 sets (1 bolt / 2 nuts, 2 washers).

The quantity for Bolt B indicate the number of 1 set (1 bolt / 1 nut, 1 washer).

Product weight list (reference)

ROTARY DAMPER (LEVER TYPE) UNIT: kg

mm	inch	ROTARY DAMPER		
		U-PVC	PP	PVDF
40	1 1/2	1.1	0.9	1.4
50	2	1.3	1.0	1.7
65	2 1/2	1.5	1.2	2.0
80	3	1.7	1.3	2.3
100	4	2.3	1.7	3.1
125	5	4.4	3.5	5.3
150	6	5.3	4.2	6.6
200	8	8.4	6.6	10.1
250	10	11.2	8.0	22.5
300	12	17.0	15.0	32.7
350	14	19.0	16.0	35.2
400	16	—	22.0	48.5
450	18	—	28.0	50.0
500	20	—	36.0	57.5
600	24	—	66.0	79.0

Product model code list

ACTUATION	TYPE	OPERATING SYSTEM	BODY MATERIAL	SEAL MATERIAL	CONNECTION	STANDARD	SIZE
V	**	LV	*	*	W	*	***
: V	: D7 TYPE 57 D6 TYPE 56 DP TYPE 75	: LV LEVER TYPE	: U U-PVC P PP F PVDF	: E EPDM V FKM	: W WAFER	: 1 JIS 10K 5 JIS 5K D DIN A ANSI	: 040 40mm : 600 600mm

Installation, Operation and Maintenance Manual

"For details of Installation, Operation and Maintenance, please contact our nearest distribution agent or sales office.