

80 (3"), 125mm (5"), 150mm (6"),
250mm (10"), 300mm (12")

100mm (4"), 200mm (8")

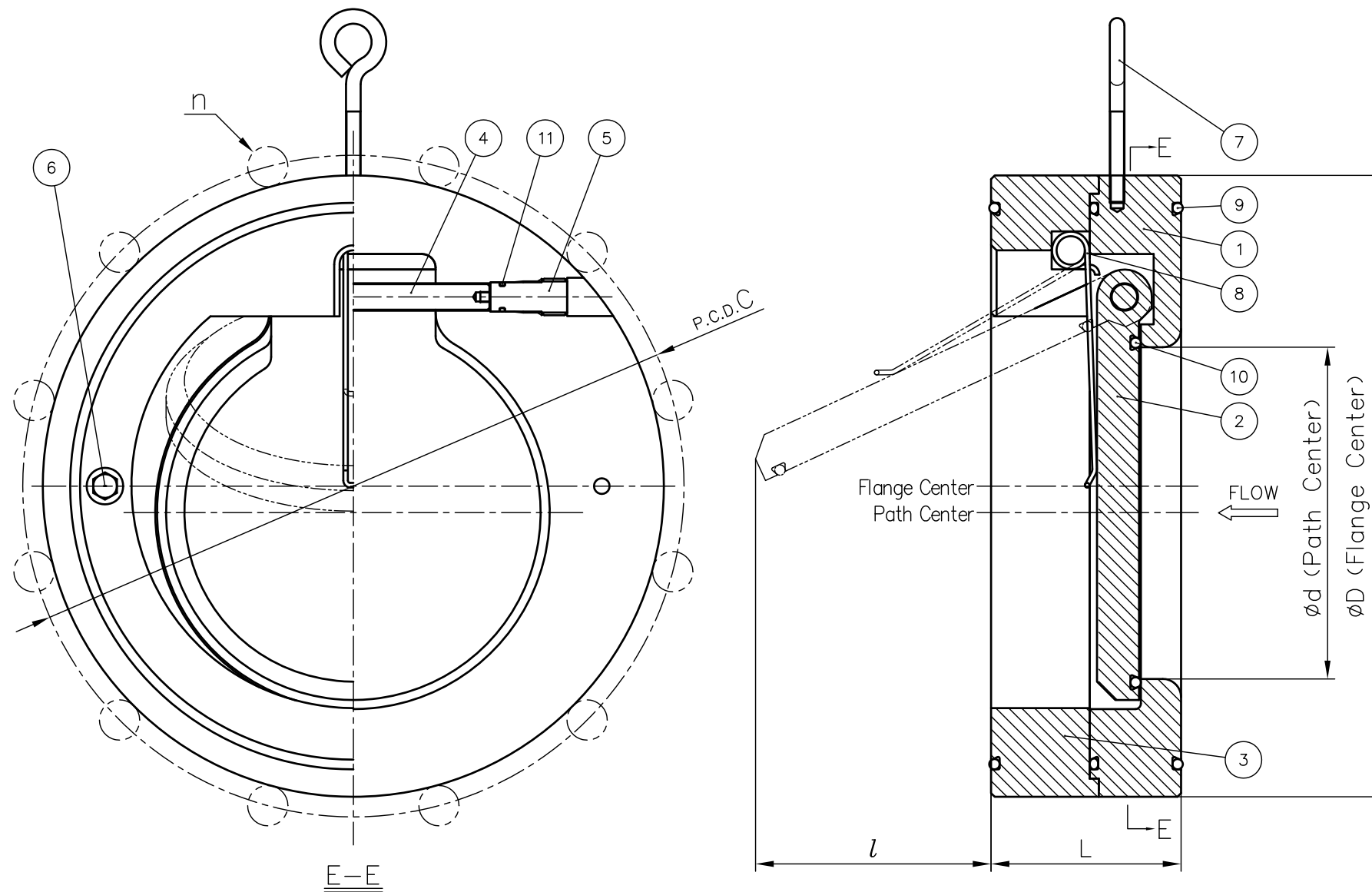

DIMENSIONS TABLE

Unit : mm

Nominal Size		DIN PN10		d	D	L	l
		C	n				
80mm	3"	160	8	47	144	63	22.6
100	4	180	8	52	175	70	34.9
125	5	210	8	77	194	76	50.9
150	6	240	8	92	220	82	64.8
200	8	295	8	132	279	101	93.6
250	10	350	12	177	333	114	129.0
300	12	400	12	217	378	115	165.6

Note. The shape and appearance of the assembly differ a little with nominal size and a connection standard of this drawing.

11	O-RING (C)	1		
10	O-RING (B)	1	□ EPDM □ FKM	
9	O-RING (A)	3		
8	SPRING	1	SWP-B	ETFE Coating
7	I BOLT	1	CHROMIZED STEEL (SS400)	Unichrome
6	BOLT	2		
5	SHAFT PLUG	1		
4	SHAFT	1	PVC	
3	STOPPER	1		
2	DISC	1		
1	BODY	1		
No.	DESCRIPTION	QTY.	MATERIAL	REMARKS
ITEM	WAFER CHECK VALVE ASS'Y SPRING TYPE DIN PN10 80mm (3") ~ 300mm (12")			
DRAWN	E.Emmei	DATE	SCALE	
CHECKED	H.Kawano	APR.11.2014	~	
APPROVED	K.Kamita	DRAWING No.		
SPECIAL ORDER No.		WC-60004DE		②
ASAHI YUKIZAI CORPORATION				