

**Compact Ball Valve
Type27
Pneumatic Actuated
Type AR
13-50mm (3/8"-2")**

User's Manual





Contents

1. Be sure to read the following warranty clauses of our product	1
2. General operating instructions	2
3. General instructions for transportation, unpacking and storage	3
4. Name of parts	4
5. Maximum working pressure vs. temperature	5
6. Specifications of actuator	6
7. Specifications of filter regulator	6
8. Specifications of solenoid valve	7
9. Specifications of limit switch box	8
10. Specifications of speed controller	8
11. Installation procedure	9
Threaded end	9
Socket end	10
12. Support setting procedure	11
13. Air piping procedure	12
14. Connection of limit switch procedure ..	14
15. Connection of solenoid valve procedure	15
16. Operating procedure	16
1) Operating procedure by air	16
2) Manual operation procedure	17
3) Adjustment of opening / closing speed procedure	18
4) Full opening adjustment procedure	20
17. Actuator removal procedure	21
18. Inspection items	22
19. Troubleshooting	23
20. How to inquire about defects or replacement	24
21. Handling of residual and waste materials	24



This user's guide contains very important information for the proper installation, maintenance and safe use of an ASAHI AV Product.

Please store this manual in an easily accessible location.

<Warning & Caution Signs>

 Warning	<p>This symbol reminds the user to take caution due to the potential for serious injury or death.</p>
 Caution	<p>This symbol reminds the user to take caution due to the potential for damage to the valve if used in such a manner.</p>

<Prohibited & Mandatory Action Signs>



	<p>Prohibited: When operating the valve, this symbol indicates an action that should not be taken.</p>
	<p>Mandatory action: When operating the valve, this symbol indicates mandatory actions that must be adhered to.</p>

1. Be sure to read the following warranty clauses of our product



- Always observe the specifications of and the precautions and instructions on using our product.
- We always strive to improve product quality and reliability, but cannot guarantee perfection. Therefore, should you intend to use this product with any equipment or machinery that may pose the risk of serious or even fatal injury, or property damage, ensure an appropriate safety design or take other measures with sufficient consideration given to possible problems. We shall assume no responsibility for any inconvenience stemming from any action on your part without our written consent in the form of specifications or other documented approval.
- The related technical documents, operation manuals, and other documentation prescribe precautions on selecting, constructing, installing, operating, maintaining, and servicing our products. For details, consult with our nearest distributor or agent.
- Our product warranty extends for one and a half years after the product is shipped from our factory or one year after the product is installed, whichever comes first. Any product abnormality that occurs during the warranty period or which is reported to us will be investigated immediately to identify its cause. Should our product be deemed defective, we shall assume the responsibility to repair or replace it free of charge.
- Any repair or replacement needed after the warranty period ends shall be charged to the customer.
- The warranty does not cover the following cases:
 - (1) Using our product under any condition not covered by our defined scope of warranty.
 - (2) Failure to observe our defined precautions or instructions regarding the construction, installation, handling, maintenance, or servicing of our product.
 - (3) Any inconvenience caused by any product other than ours.
 - (4) Remodeling or otherwise modifying our product by anyone other than us.
 - (5) Using any part of our product for anything other than the intended use of the product.
 - (6) Any abnormality that occurs due to a natural disaster, accident, or other incident not stemming from something inside our product.

* Note that damage induced by a defect of our product is not covered by warranty.
- This guarantee applies to the use of our product only in Japan. If it is used overseas, please inquire with us separately.





2. General operating instructions

- 
Warning
 - Never attempt to disassemble an actuator and valve.
 - Using a positive-pressure gas with our plastic piping may pose a dangerous condition due to the repellent force particular to compressible fluids even when the gas is under similar pressures used for liquids. Therefore, be sure to take the necessary safety precautions such as covering the piping with protective material. For inquiries, please contact us. For conducting a leak test on newly installed piping, be sure to check for leaks under water pressure. If absolutely necessary to use a gas in testing, please consult your nearest service station beforehand.
 - A ball-type valve structurally has a dead space. Be careful of volatile liquids such as hydrogen peroxide solution (H₂O₂) and sodium hypochlorite (NaClO) because those liquids may turn into gas in the dead space and cause an abnormal rise of pressure in the valve. The gas that causes an abnormal rise of inner pressure thorough vaporization is compressible fluid. So, if the valve breaks, its fragments explosively scatter, and it is very dangerous.
- 
Caution
 - Do not step on or apply excessive weight on valve. (It can be damaged.)
 - Keep the valve away from excessive heat or fire. (It can be damaged, or destroyed.)
 - Do not use the valve to fluid containing slurry. (The valve will not operate properly.)
 - Do not use AV valves in a place where they may become submerged in water.
 - Do not remove a dust-proof cap provided to piping port before piping work starts.
 - Be careful of the environment where the valve is installed. In particular, avoid places exposed to salty wind, corrosive gas, chemical solution, sea water, steam, etc.
 - Do not apply a great impact or vibration to the actuator. (Any such practice may result in breakdown.)
- 
 - Use the valve working pressure, working temperature, ambient temperature within an allowable range. (The valve can be damaged or deformed by operating beyond the allowable range.)
 - Allow sufficient space for maintenance and inspection.
 - Select a valve material that is compatible with the media. For chemical resistance information, refer to “CHEMICAL RESISTANCE ON ASAHI AV VALVE”. (Some chemicals may damage incompatible valve materials.)
 - Do not use the valve in conditions where the fluid may have crystallized. (The valve will not operate properly.)
 - Keep the valve out of direct sunlight, water and dust. Use cover to shield the valve. (The valve will not operate properly.)
 - Be careful not to allow foreign matters, water droplets, oil, and other substances to enter from the air pipe opening and intake/exhaust hole of the actuator. (In areas that are likely to have snow, melted water of snow that falls on the valve may enter from the air pipe opening and intake/exhaust hole of the actuator.)
 - Perform periodic maintenance. (Leakage may develop due to temperature changes or over periods of prolonged storage, rest or operation.)
 - When installing the valve, provide an appropriate support. (Failure to do so may cause breakage due to excessive force applied to the valve body and pipes.)
 - The AV valves must be used within the specifications specifically applicable to the product. (May not work.)

General operating instructions (continued)

- If the actuator is used in an environment below 5°C temperature, its operating fluid must be free from the water and moisture contained in it because of possible problems due to the freeze.
- When you use the valve in a low-temperature environment, put a cover or such that covers the entire actuator to prevent it from freezing, and check the operating conditions on a regular basis. (If it freezes, it does not operate normally.)
- Use dehumidified and dust-removed clean operation air. When using highly dry air at a dew point of -40°C or less, please consult us separately.
-   - When removing the actuator, be sure to use the "Base plate removing jig". (Failure to so may cause, damage the Base plate.)
- Regarding the ball valve type, we recommend that you use fully open or fully closed. This is because the edge of the ball opening remains on the seat (PTFE) when used at an intermediate opening, so that the sealing performance temporarily deteriorates at the time of full closing.

3. General instructions for transportation, unpacking and storage

-   - When suspending and supporting a valve, take care and do not stand under a suspended valve.
-   - This valve is not designed to handle impacts of any kind. Avoid throwing or dropping the valve.
- Avoid scratching the valve with any sharp object.
- Do not over-stack cardboard shipping boxes. Excessively stacked packages may collapse.
- Avoid contact with any coal tar creosote, insecticides, vermicides or paint. (These chemicals may cause damage to the valve.)
-  - Store products in their corrugated cardboard boxes. Avoid exposing products to direct sunlight, and store them indoors (at room temperature). Also avoid storing products in areas with excessive temperatures. (Corrugated cardboard packages become weaker as they become wet with water or other liquid. Take care in storage and handling.)
- After unpacking the products, check that they are defect-free and meet the specifications.

4. Name of parts

13-50mm (3/8"-2")

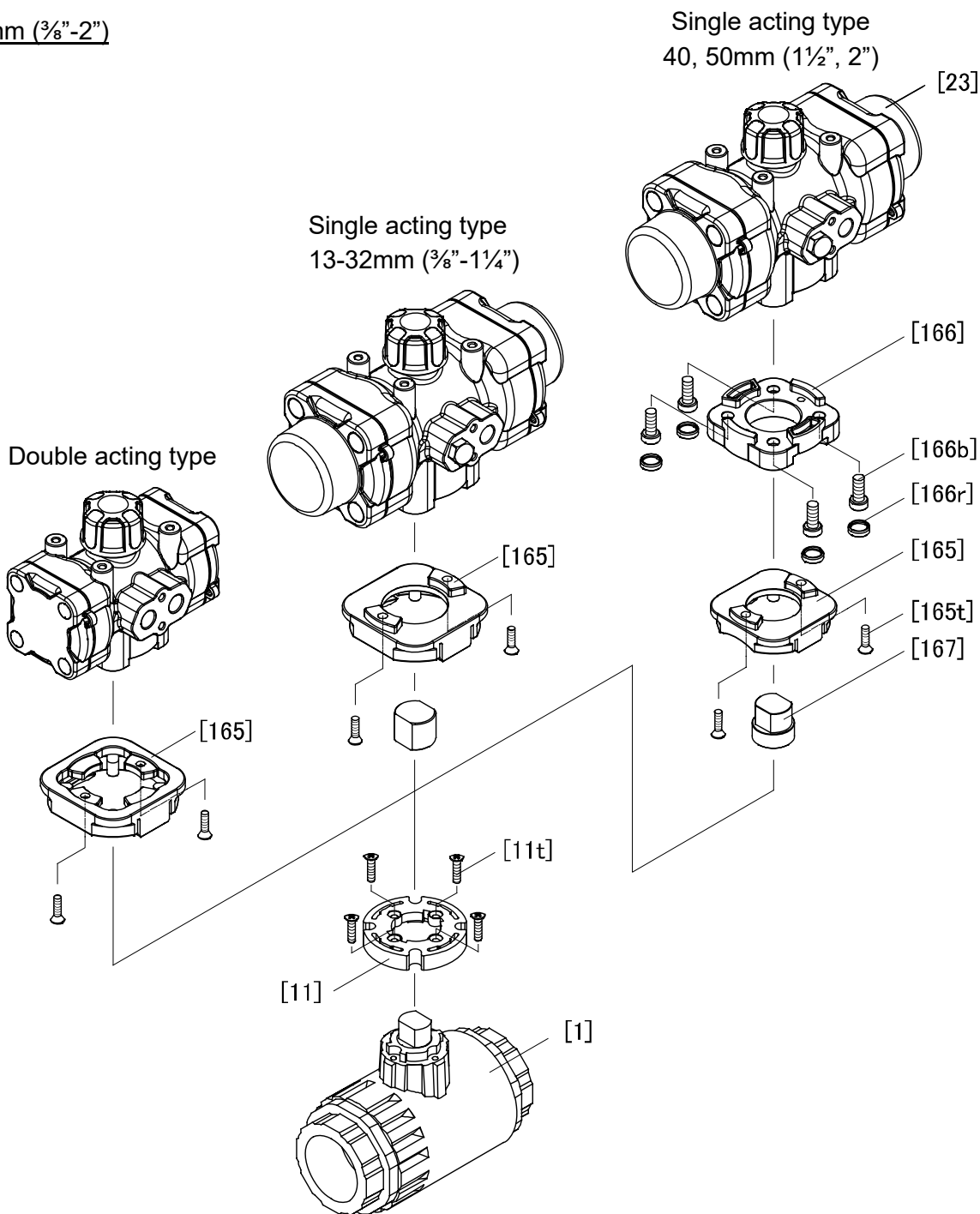

[1]	Compact ball valve type27	[165t]	Tapping screw
[11]	ISO plate	[166]	Connector plate
[11t]	Tapping screw	[166b]	Bolt
[23]	Actuator	[166r]	Rubber cap
[165]	Base plate	[167]	Shaft adapter

5. Maximum working pressure vs. temperature

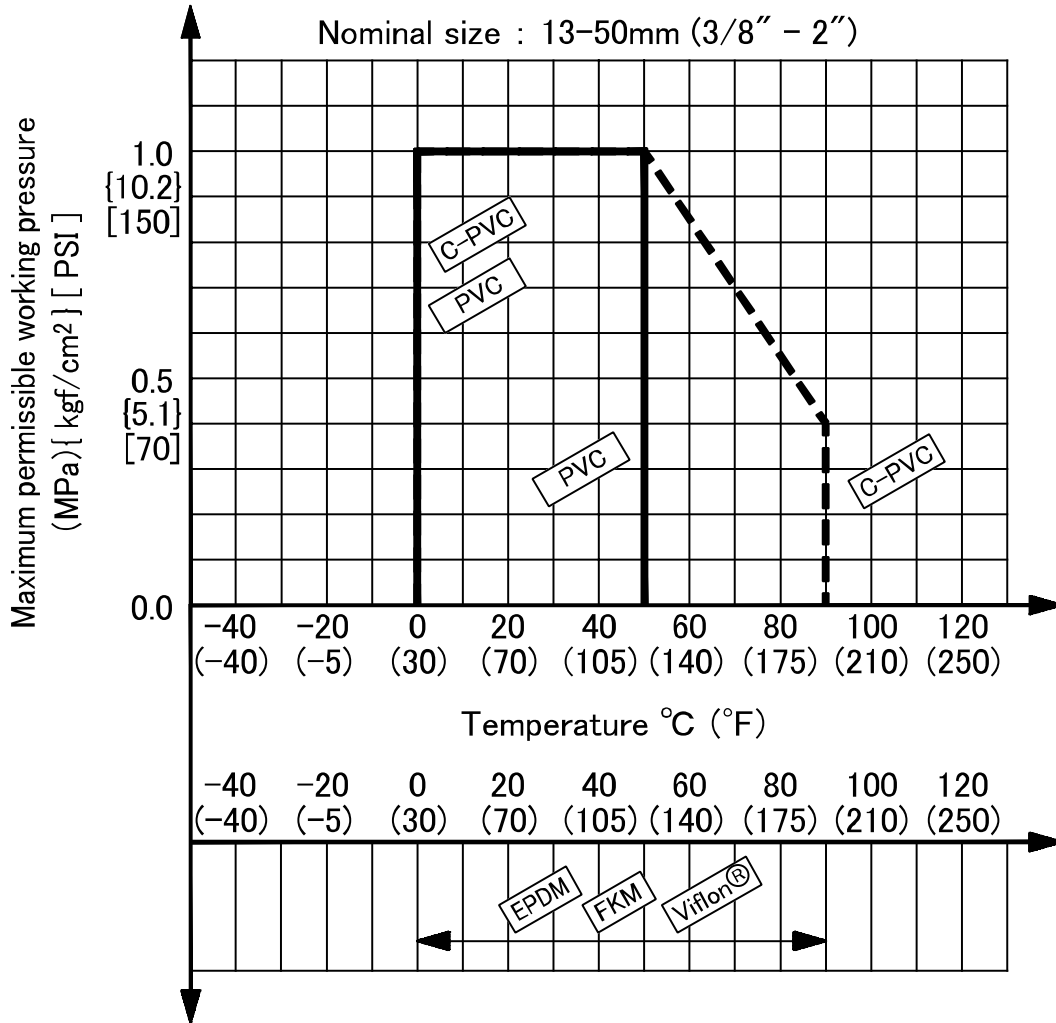

6. Specifications of actuator

Actuation	Nominal size	Actuator type	Air consumption NL per 1 open & shut at 0.4MPa	Air supply bore
Double acting	13, 15mm ($\frac{3}{8}$ " , $\frac{1}{2}$ ")	AR032DA10	0.3	Rc 1/8
	20, 25mm ($\frac{3}{4}$ " -1")	AR032DA11		
	32mm ($\frac{1}{4}$ ")	AR040DA20	0.6	
	40, 50mm ($\frac{1}{2}$ " -2")	AR050DA30	1.3	
Air to open	13-25mm ($\frac{3}{8}$ " -1")	AR040NC20	0.2	Rc 1/8
	32mm ($\frac{1}{4}$ ")	AR050NC30	0.4	Rc 1/4
	40, 50mm ($\frac{1}{2}$ " -2")	AR063NC40	0.8	
Air to shut	13-25mm ($\frac{3}{8}$ " -1")	AR040NO20	0.2	Rc 1/8
	32mm ($\frac{1}{4}$ ")	AR050NO30	0.4	Rc 1/4
	40, 50mm ($\frac{1}{2}$ " -2")	AR063NO40	0.8	

Actuation	Nominal size	Angle adjustment range*1	Standard operating pressure	Ambient temperature range
Double acting Air to open Air to shut	13-50mm ($\frac{3}{8}$ " -2")	Cannot adjust an angle	0.4-0.7 MPa {4.1-7.1 kgf/ cm ² } [70-105 psi]	-10 to 60°C [14 to 150°F]

*1 ; A product without full opening adjustment mechanism cannot adjust an angle. A product with full opening adjustment mechanism can be adjusted to an arbitrary opening in a range between 0 and 45 deg. Refer to the page of "Full opening adjustment procedure" for the full opening adjustment method.

7. Specifications of filter regulator

Actuation	Nominal size	Type sign	Air supply bore	Element rated filtration
Double acting Air to open Air to shut	13-50mm ($\frac{3}{8}$ " -2")	ARU2-02-8A-G	Rc1/4	5µm

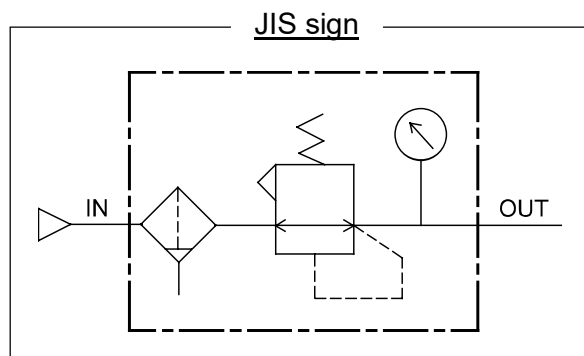

8. Specifications of solenoid valve

Actuation	Nominal size	Type sign	Power consumption
Double acting Air to open Air to shut	15-50mm (1/2"-2")	4N3S102K-W□-G31193	AC:6VA DC:5.5W
		4N3S102K-D□-G31193	

Actuation	Air supply bore	Effective cross section	Additional functions
Double acting Air to open Air to shut	Rc1/4	10mm ² or more	- Built-in bypass valve - Silencer with throttle valve attached (to be used as speed controller)

4N3S102K-□ □-G31193

Sign	Protection level	sign	Specification
W	Water tight cover type (Equivalent to IP 55)	1	100V AC 50/60Hz
D	DIN connector type (Equivalent to IP 55)	(2)	110V AC 50/60Hz
		3	200V AC 50/60Hz
		(4)	220V AC 50/60Hz
		5	24V DC
		(6)	48V DC
		(7)	100V DC
		(8)	125V DC
		(9)	110V DC

() is special order.

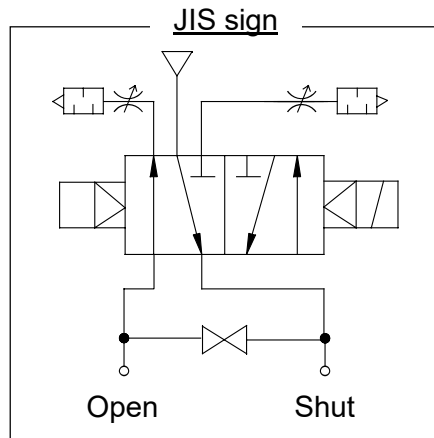
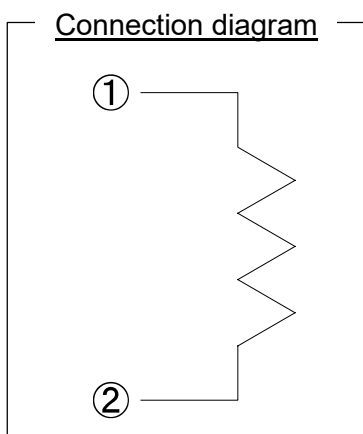

9. Specifications of limit switch box

Actuation	Nominal size	Type sign	Switch contact	Protection grade
Double acting Air to open Air to shut	13-50mm ($\frac{3}{8}$ "-2")	CFC-6301	Silver contact	IP67 (IEC529)
		CFC-6302	Gold contact (Micro-load)	

Ratings

Type sign	Rated voltage	Max current
CFC-6301	250V AC	10 A
	24V DC	2.5 A
CFC-6302	250V AC	0.1 A
	24V DC	0.1 A

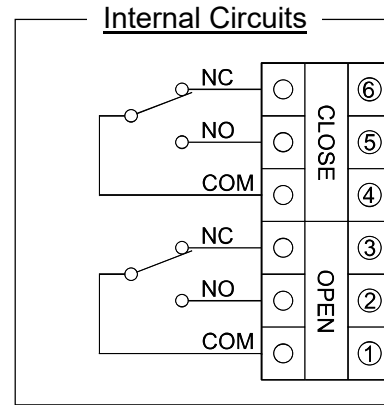

10. Specifications of speed controller

Actuation	Nominal size	Actuator type	Air supply bore	Type sign	Applicable tube outer diameter (mm)	Number of needle rotations
Double acting	13, 15mm ($\frac{3}{8}$ ", $\frac{1}{2}$ ")	AR032DA10	Rc1/8	AS2201FG-01-06A	$\phi 6$	11 turns
	20, 25mm ($\frac{3}{4}$ ", 1")	AR032DA11				
	32mm (1 $\frac{1}{4}$ ")	AR040DA20				
Air to open Air to shut	15-25mm ($\frac{1}{2}$ "-1")	AR040NC20 AR040NO20				
Double acting	40, 50mm (1 $\frac{1}{2}$ ", 2")	AR050DA30	Rc1/4	AS2201FG-02-06A	$\phi 6$	11 turns
Air to open Air to shut	32mm (1 $\frac{1}{4}$ ")	AR050NC30 AR050NO30				
	40, 50mm (1 $\frac{1}{2}$ ", 2")	AR063NC40 AR063NO40				

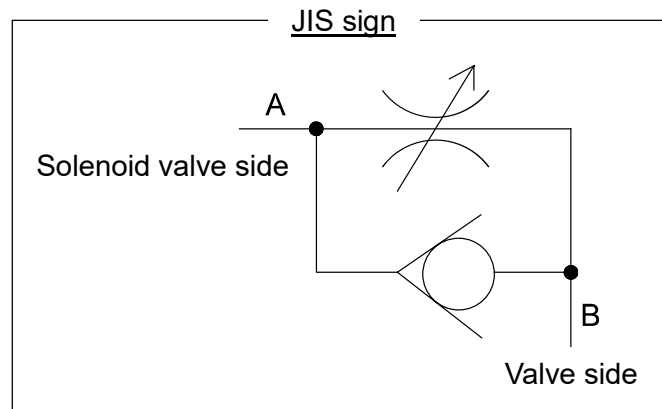

11. Installation procedure



Warning

- When suspending and supporting a valve, take care and do not stand under a suspended valve.
- ! - Be sure to conduct a safety check on all hand and power tools to be used before beginning work.
- When conducting piping work, wear personal protective equipment appropriate to the contents of work. (Failure to do so may cause an injury.)
- ! - When installing pipes and valves, ensure that they are not subjected to tension, compression, bending, impact, or other excessive stress.
- When connecting an ASAHI AV Valve to metal piping, take care not to let the pipe stress on the ASAHI AV Valve.

Threaded End (PVC, C-PVC)



Caution

- Avoid excessive tightening. (The valve can be damaged.)
- Do not use the pipe wrench. (The valve can be damaged.)
- Make sure that the threaded connections are plastic x plastic. (Metallic thread can cause damage.)
- Wrap the threaded joints on our plastic piping with sealing tape. Using a liquid sealing agent or liquid gasket may cause stress cracks (Environmental Stress Cracking). Our product warranty shall not apply in case of said use, even when said use is unavoidable.

Necessary items



- Sealing tape
- Spanner wrench or Motor wrench

Procedure

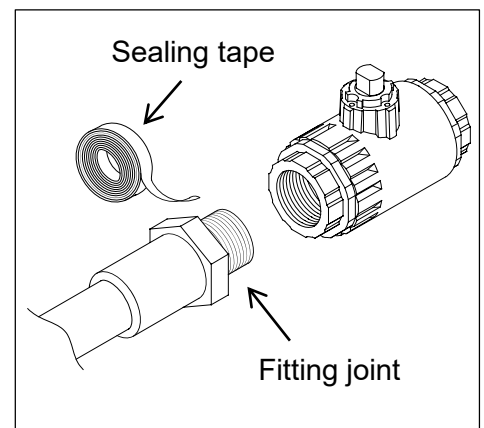
- 1) Wind a sealing tape around the external thread of joint, leaving the end (about 3mm) free.
- 2) Tighten the male thread of fitting and the female thread of valve hardly with hand.
- 3) Using a spanner wrench or motor wrench, screw in the valve by turning 180° -360° carefully without damaging it.



Socket End (PVC, C-PVC)

- Warning**  - When using an adhesive, ventilate the space sufficiently, prohibit the use of a fire in the vicinity, and do not inhale adhesive vapors directly.
- !** - If an adhesive gets into contact with your skin, wash it off immediately. If you feel sick or find anomaly, receive a physician's diagnosis and take appropriate measures promptly.
- Caution**  - Do not under any circumstances try to insert a pipe into another fitting or valve by striking it. (Which may break the piping.)
- Caution**  - Take care in doing work at low temperatures. Solvent vapors are hard to evaporate and are likely to remain. (Solvent cracks may occur, damaging the equipment.)
- After assembling the piping system, open both ends of the piping and use a fan (of the Low-Voltage Type) or something similar to ventilate the space, thus removing the solvent vapors.
- Do not apply more adhesive than necessary. (The valve can be damaged due to solvent cracking.)
 - Use the appropriate ASAHI AV cement.
 - Conduct a water test at least 24 hours after joining the pipes with an adhesive.

Necessary items

- ASAHI AV cement
- Waste cloth

Procedure

- 1) Make sure the hub part of the valve is clean with waste cloth.
- 2) Apply adhesive evenly to the hub part of the valve and the pipe spigot.

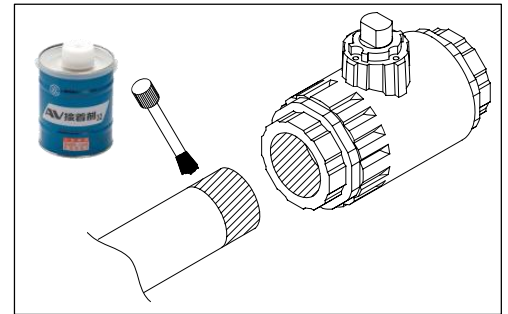

- Caution**  - Do not apply more adhesive than necessary. (The valve can be damaged due to solvent cracking.)

Adhesive quantity (guideline)

Nominal size	13mm ($\frac{3}{8}$ "	15mm ($\frac{1}{2}$ "	20mm ($\frac{3}{4}$ "	25mm (1"	32mm ($1\frac{1}{4}$ "	40mm ($1\frac{1}{2}$ "	50mm (2"
Quantity (g) [oz]	0.8 [0.028]	1.0 [0.035]	1.3 [0.046]	2.0 [0.071]	2.4 [0.085]	3.5 [0.123]	4.8 [0.169]

- 3) After applying adhesive, insert the pipe quickly to the valve and leave it alone for at least 60 seconds.
- 4) Wipe away overflowing adhesive.

12. Support setting procedure



Caution - When installing a pipe support by means of a U-band or something similar, take care not to over-tighten. (Excessive force may damage the pipe.)

Necessary items

- Spanner wrench
- U-type clamp (with bolt)
- Rubber sheet

Level plumber

- 1) Spread the rubber sheet under the valve, and support with stand.
- 2) Spread the rubber sheet on the pipe and secure pipe with U-type clamp.

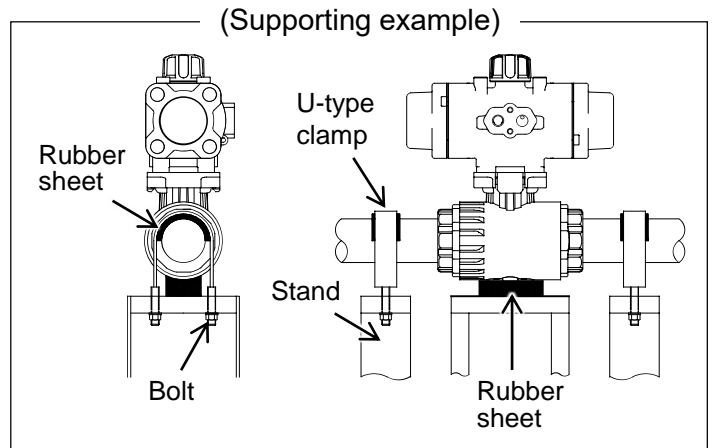

Perpendicular plumber

- 1) Spread the rubber sheet under the actuator, and support with stand.
- 2) Spread the rubber sheet on the pipe and secure pipe with U-type clamp.

The conditions and nominal size that do not require actuator support are as follows.

- a) Specifications of actuator
 - Without options
 - With standard speed controller
 - With standard limit switch box

b) Nominal size (mm [inch])

Actuation	13 [3/8]	15 [1/2]	20 [3/4]	25 [1]	32 [1 1/4]	40 [1 1/2]	50 [2]
Double acting	○	○	○	○	○	○	○
Air to open Air to shut	○	○	○	○	/	/	/

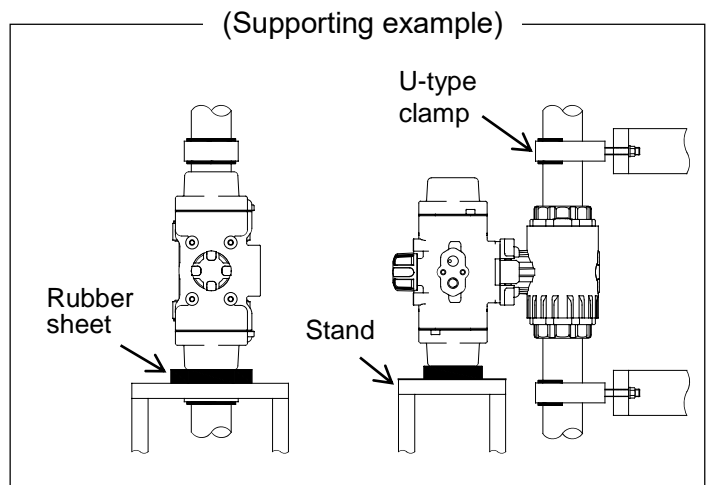

13. Air piping procedure



- Do not remove a dust-proof cap provided to piping port before piping work starts.
 - Avoid excessive tightening for joint. (The threaded area can be damaged.)



- Check the connection locations, air pipe sizes, and screw types with the approved drawings and other documents for the product. Then lay the air piping.
 - Use dehumidified and dust-removed clean operation air. When using highly dry air at a dew point of -40°C or less, please consult us separately.
 - If the actuator is used in an environment below 5°C temperature, its operating fluid must be free from the water and moisture contained in it because of possible problems due to the freeze.



- Steel pipes must always be of the plated.
 - Before installing an actuator in pipeline, flash the inside of pipeline completely.
 - When connecting the air piping, be careful not to let foreign matter inside the piping.
 - Threaded area of a pipe must be free from the sharp edges and burr.

Necessary items

- Steel pipe or tube for piping
- Joint for steel pipe or tube
- Spanner wrench
- Sealing tape

<For a standard type and an attached speed controller type >

Procedure

- 1) Wind a sealing tape around the external thread of joint, leaving the end (about 3mm) free.
- 2) Screw the joint in the piping female screw of the actuator by hand fully.
- 3) Screw the joint one turn with a spanner wrench.



- Avoid excessive tightening for joint. (The threaded area can be damaged.)

- 4) Mount a steel pipe or a tube.

Standard type or with speed controller	Double acting		Air to open / Air to shut	
	AR032DA10 AR032DA11 AR040DA20	AR050DA30	AR040NC20 AR040NO20	AR050NC30 AR050NO30 AR063NC40 AR063NO40
Standard type				
With speed controller				

<For a solenoid valve and a filter regulator>

- ! - Set the secondary pressure of the filter regulator to meet the equipment specification. (Failure to do so may cause a malfunction and failure.)
- Discharge drain of the filter regulator regularly.

Necessary items

- Steel pipe or tube for piping
- Joint for steel pipe or tube
- Spanner wrench
- Sealing tape

Procedure

- 1) Wind a sealing tape around the external thread of joint, leaving the end (about 3mm) free.
- 2) Screw the joint in the piping female screw of the actuator by hand fully. (Refer to the lower fig.)
- 3) Screw the joint one turn with a spanner wrench.

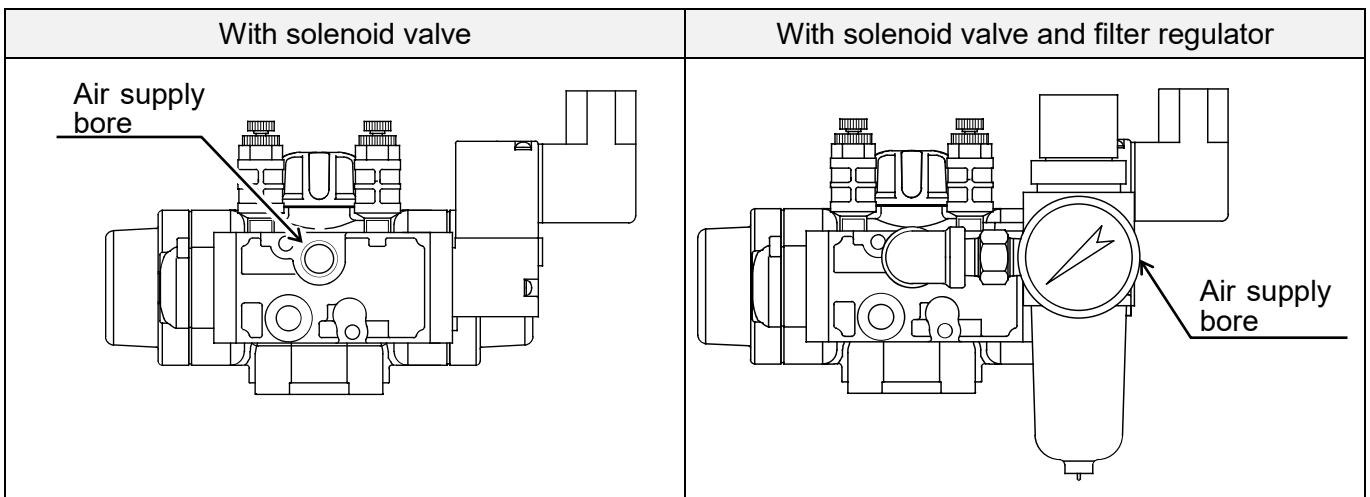

⚠️ - Avoid excessive tightening for joint. (The threaded area can be damaged.)
 Caution

- 4) Mount a steel pipe or a tube.



14. Connection of limit switch procedure

<CFC-6301, CFC-6302>

-  - Shut down the power on the equipment before connecting or disconnecting wires. (There are risks of electrical shock depending on machine start suddenly.)
-  - Be sure that the terminal cover and body cover are put on during the operation.
-  - Firmly tighten the cover. (Rainwater etc. will invade and cause breakdown.)

Necessary items

- Phillips head screw driver
- Flathead screw driver
- Wire stripper
- Connector (G1/2)

Procedure



- 1) Loosen the four screws used to attach the limit switch cover with a Phillips head screwdriver and remove cover from the limit switch. (The screw is made so that it will not detach from the cover.)
- 2) Remove a protective cover made of resin.
- 3) Draw a cable through the connector.
- 4) Strip cable with a wire stripper.
- 5) Connect terminal screw with a flat head screwdriver according to the internal circuit diagram shown in Specifications of limit switch.

-  - Tighten the screws. (If not, electric leaks or shocks may occur.)

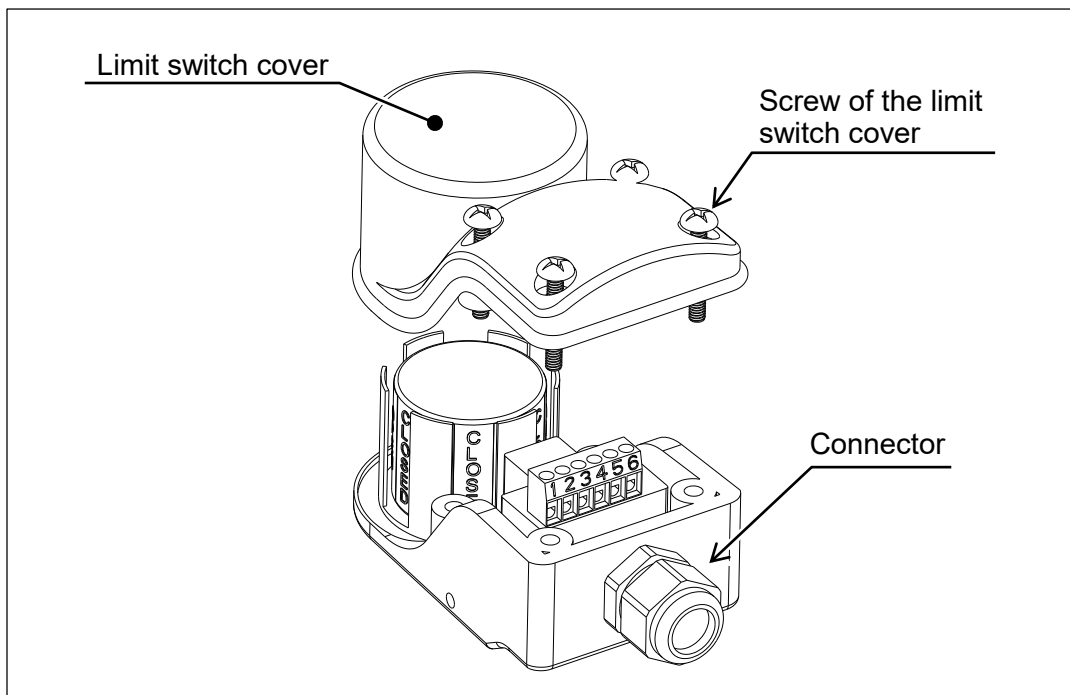
- 6) Tighten the above four screws with a Phillips head screwdriver to install cover on the limit switch.
- 7) Tighten the cable by connector.



15. Connection of solenoid valve procedure



- Caution**   - Shut down the power on the equipment before connecting or disconnecting wires. (There are risks of electrical shock depending on the level of operating voltage.)
- Check the solenoid voltage and supply voltage.

Necessary items

- Phillips head screw driver
- Terminal crimping tool
- Wire stripper
- Connector (G1/2)

Procedure

- 1) Loosen the cover setting screw by Phillips head screw driver, and remove the cover.



- Caution**   - Don't loss O-ring. (Short circuit or shocks may occur.)

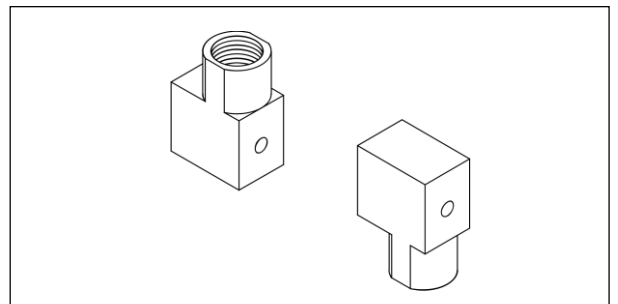
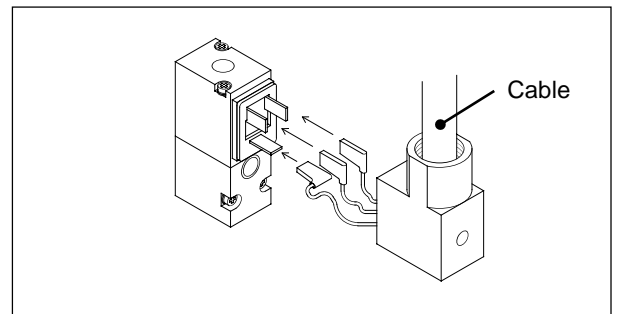
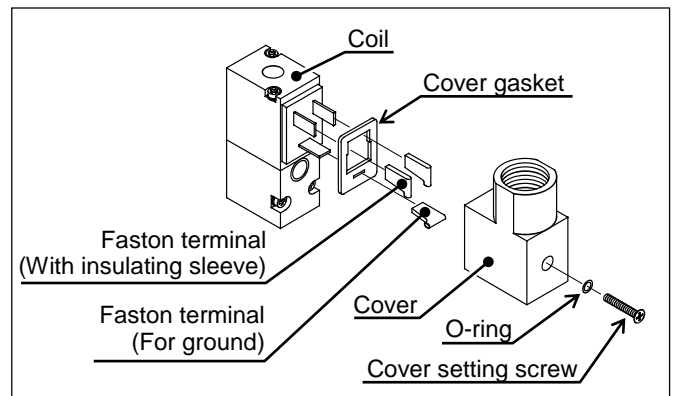

- 2) Remove the Faston terminal inserted into coil side and the insulating sleeve. (Insulating sleeve isn't attached in Faston terminal.)
- 3) Draw the cable through the connector to the cover.
- 4) Strip cable with a wire stripper.
- 5) Draw the lead wire through the cover.
- 6) Install the Faston terminal on the lead wire with a terminal-crimping tool.
- 7) Insert the Faston terminal into the coil side, and fit the cover. (DC power supply, there is no polarity.)
- 8) Tighten the cover setting screw to fix it. (The cover can be set with the wire extraction opening turned upward or downward.)
- 9) Tighten the cable by connector.



16. Operating procedure

1) Operating procedure by air

  - Confirm that a wrench for manual operation is not fitted into the output shaft located in the upper part of the actuator.

  - The AV valves must be used within the specifications specifically applicable to the product. (May not work.)

Procedure

- 1) Supply air to the air supply opening.
- 2) Check that the air supplying side and the indicator position are matching.
- 3) Stop supplying air.

Full open and full shut Indication

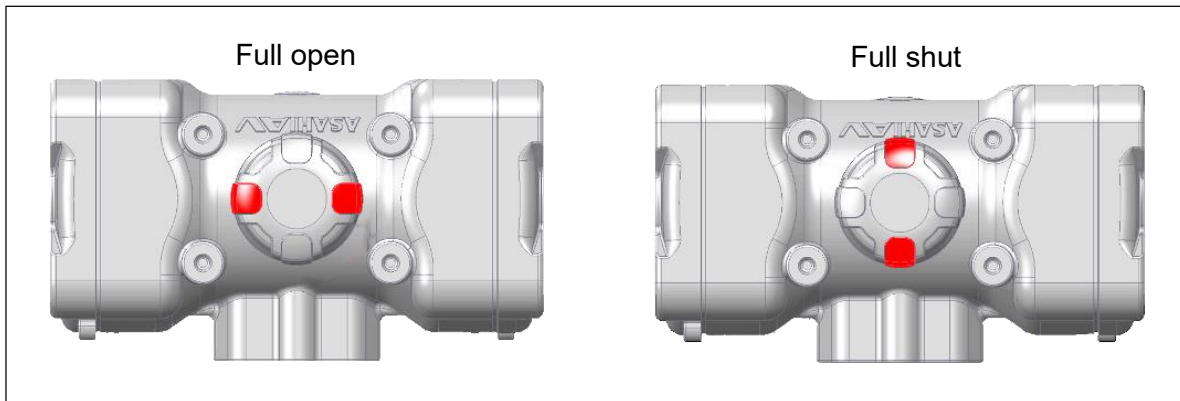

<With solenoid valve>

Procedure

- 1) Supply the air to the solenoid valve.
- 2) Push the button with a finger, and confirm the action mode shown in the under table.
- 3) Apply regular rated voltage to the solenoid valve, and confirm the action mode shown in the following table.
- 4) Turn off the solenoid valve.
- 5) Stop supplying air to the solenoid valve.

Button	Currents	Double acting Air to open	Air to shut
Push	On	Open	Shut
Not push	Off	Shut	Open

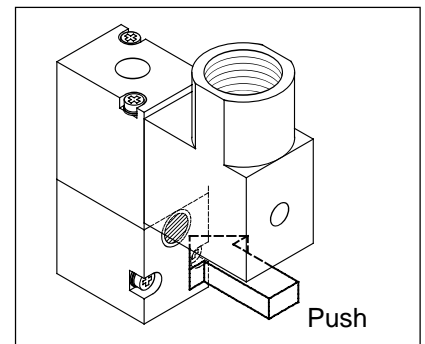

2) Manual operation procedure (double acting only)



Warning

- Don't supply air during manual operation. (When air is supplied during the manual operation, you may be injured.)



Caution

- Do not forcibly rotate the spanner from the fully open or fully closed position. (It breaks down.)

Necessary items



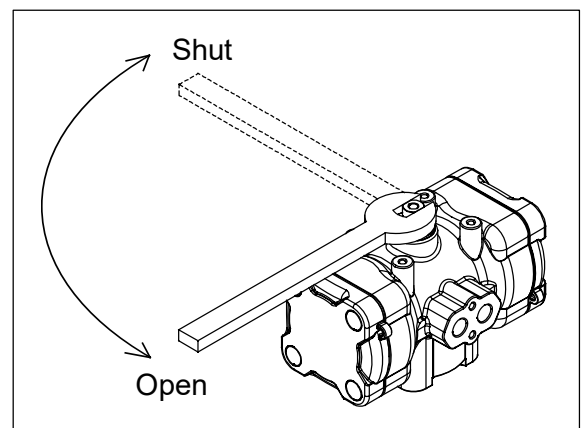
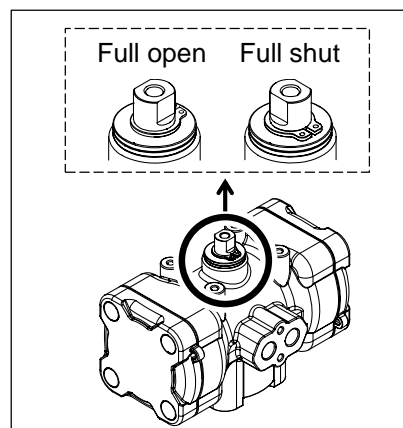
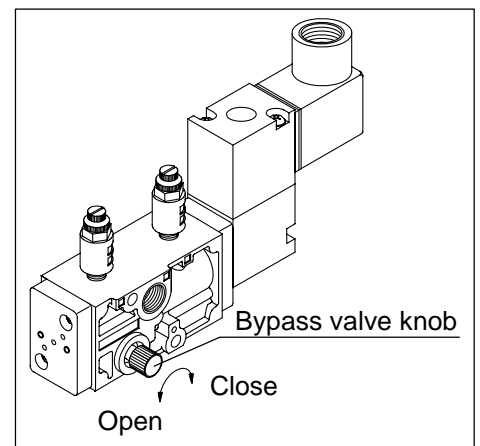
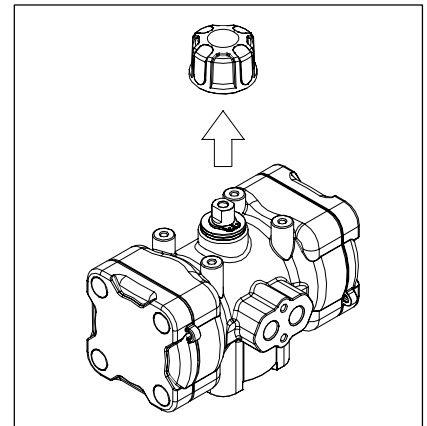

- Spanner wrench

Procedure

- 1) Close main valve for air and turn off the solenoid valve.
- 2) Turn the bypass valve knob counterclockwise, discharge air from the actuator.
- 3) Check the direction (full open or full shut) of the indicator before manual operation, and then pull the indicator attached to the output shaft on the top of the actuator to remove it.
- 4) Fit the wrench to the output shaft on the top of the actuator, and handle the wrench while checking the direction of the output shaft. (When the width across flat of the output shaft is parallel to the piping direction, open state.)
- 5) Return it to the state before the manual operation is performed (full open or full shut), and remove the wrench from the output shaft on the top of the actuator.
- 6) Fit the indicator to the output shaft on the top.
- 7) Turn the knob of the bypass valve in the clockwise direction to close the bypass valve.
- 8) Open the master valve for operation air to supply air to the solenoid valve.



3) Adjustment of opening / closing speed procedure

-   - Be sure to lock the handle (adjustment knob) of the speed controller after adjustment.
-   - Avoid excessive tightening of the handle (adjustment knob) of the speed controller.
(The speed controller can be damaged.)

<Double acting type>

Procedure

- 1) Supply the air to the solenoid valve.
- 2) Open and close unlock the handle (adjustment knob) of both speed controllers.
 - In case of model AS2201FG, pull it up the handle with fingers.
 - In case of solenoid valve, hold the adjustment knob with fingers and loosen the lock nut with a wrench.
- 3) Rotate the handle (adjustment knob) clockwise until it stops turning.
- 4) Open the solenoid valve by energizing it.
- 5) Rotate the handle (adjusting knob) of the open side speed controller little by little counterclockwise.
- 6) Turn off solenoid valve and perform closing operation.
- 7) Rotate the handle (adjusting knob) of the close side speed controller little by little counterclockwise.
- 8) Repeat item 4) to 7) to adjust the opening / closing speed required.
- 9) Open and close lock the handle (adjustment knob) of both speed controllers.
 - In case of model AS2201FG, push the handle with fingers.
 - In case of solenoid valve, hold the adjustment knob with fingers and fasten the lock nut with a wrench.

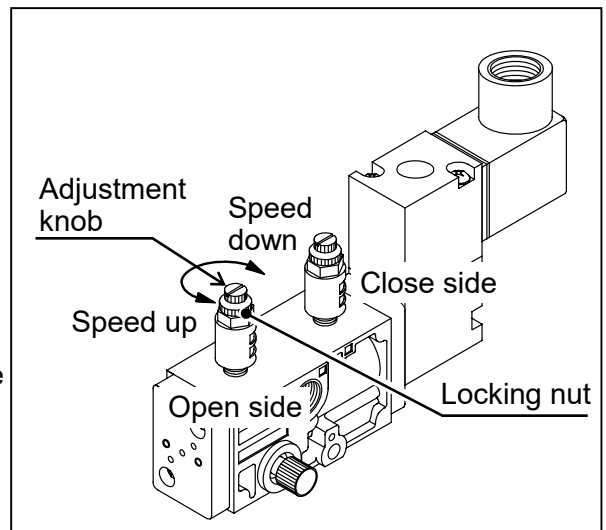
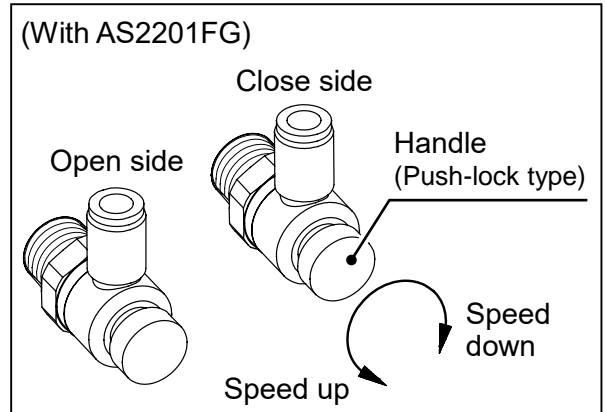

<Air to open type / Air to shut type >

The actuation type changes the speed-adjustable direction.

actuation type	Opening speed	Closing speed
Air to open	× Not adjustable	○ Adjustable
Air to shut	○ Adjustable	× Not adjustable

Procedure

- 1) Supply the air to the solenoid valve.
- 2) Unlock the handle (adjustment knob) of speed controller.
 - In case of model AS2201FG, pull it up the handle with fingers.
 - In case of solenoid valve, hold the adjustment knob with fingers and loosen the lock nut with a wrench.
- 3) Rotate the handle (adjustment knob) clockwise until it stops turning.
- 4) Energize the solenoid valve.
 - Air to open is fully open.
 - Air to shut is fully close.
- 5) After the valve is activated, turn off the solenoid valve.
- 6) Rotate the handle (adjusting knob) of the speed controller little by little counterclockwise.
- 7) Repeat item 4) to 6) to adjust the speed required.
- 8) Lock the handle (adjustment knob) of speed controller.
 - In case of model AS2201FG, push the handle with fingers.
 - In case of solenoid valve, hold the adjustment knob with fingers and fasten the lock nut with a wrench.

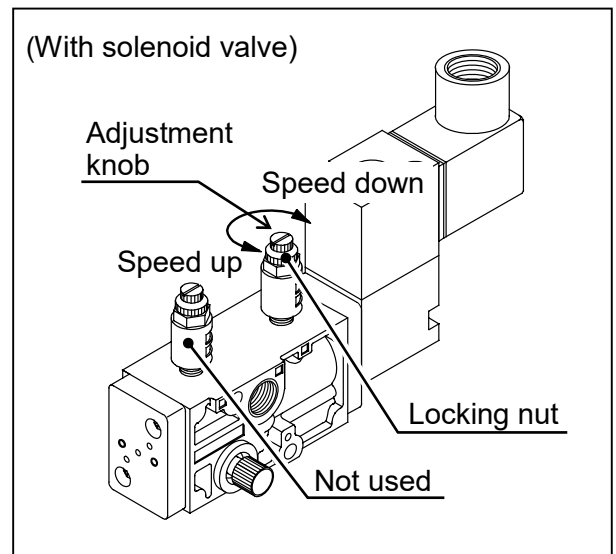
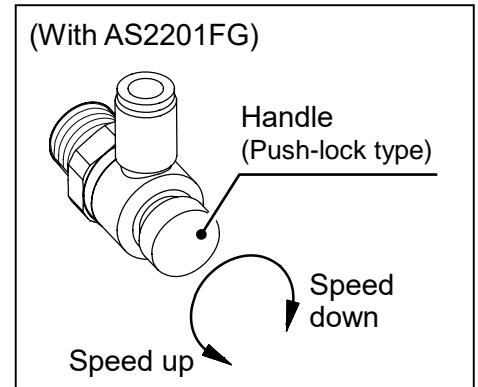

4) Full opening adjustment procedure

Necessary items

- Spanner wrench

Procedure

- 1) Manually rotate the full opening adjustment covers both on the right and left sides in the counterclockwise direction to remove them from the cylinder covers.
- 2) Loosen the nuts both on the right and left sides with a wrench, and rotate the bolts both on the right and left sides in the counterclockwise direction about 5 revolutions with the wrench.
- 3) After supplying air to the opening side of the actuator, rotate the bolts both on the right and left sides in the clockwise direction about a half to a full revolution with the wrench to confirm that the bolts can turn.
- 4) With air still supplied, rotate the bolts both on the right and left sides in the clockwise direction with the wrench until the bolts will not turn any more.

 - Do not rotate the bolts forcibly. (It may cause the actuator to be broken and cause injuries.)

- 5) Release air from the actuator.
- 6) Refer to the following table "Adjustment angle and the number of rotations of the bolt (rough target)" to check the number of rotations of the bolt appropriate for the angle you want to adjust to.
- 7) Rotate the bolt on one side in the clockwise direction with the wrench up to the number of rotations checked with the following table, and rotate the nut with the wrench to secure the bolt. (Leave the bolt on the other side as it is.)
- 8) Supply air to the opening side of the actuator.
- 9) Rotate the bolt on the other side in the clockwise direction with the wrench until it will not turn any more, and rotate the nut with the wrench to secure the bolt.

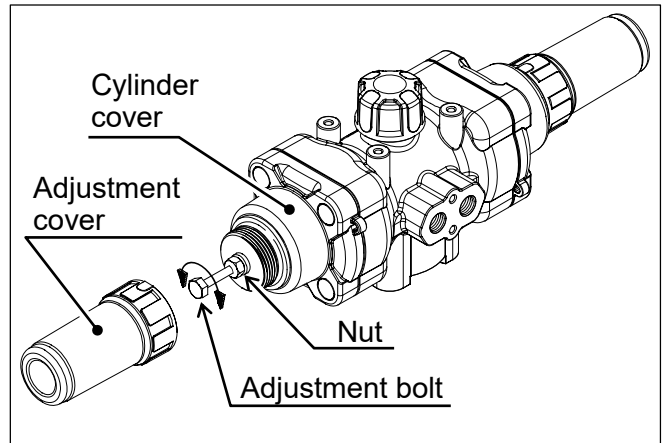

 - Do not rotate the bolts forcibly. (It may cause the actuator to be broken and cause injuries.)

- 10) Release air from the actuator.
- 11) Manually rotate the full opening adjustment covers both on the right and left sides in the clockwise direction to attach to the cylinder covers.

Adjustment angle and the number of rotations of the bolt (rough target)

Unit : Rotation

Adjustment angle Model	5°	10°	15°	20°	25°	30°	35°	40°	45°	Nut tightening torque N·m {kgf·cm} [lb·inch]
AR040□□□□	1	2+¼	3+¼	4+¼	5+½	6+½	7+¾	8+¾	9+¾	3.0 {30.6} [26.6]
AR050□□30	1	2	3+¼	4+¼	5+¼	6+¼	7+¼	8+½	9+½	5.2 {53.0} [46.0]
AR063□□40	1+¼	2+¼	3+¼	4+½	5+½	6+¾	7+¾	9	10	12.5 {127.5} [110.7]

17. Actuator removal procedure

- 

- When removing the actuator, be sure to use the "Base plate removing jig". (Failure to do so may cause damage to the Base plate.)
- 

- When removing the base plate from the valve, avoid applying excessive force to a base plate removing jig to force the claw to open. (It may cause the claw to be broken.)
- 

- Avoid excessive repetition of attaching and removing the base plate. (It may cause the claws of the base plate to have fatigue fracture.)

 - A single-action type has a metal joint (shaft adapter) between the valve and actuator. Be careful of the shaft adapter's jumping out and falling when removing the base plate from the valve.
 - Be careful not to apply excessive load to the pipe and valve when attaching and removing the base plate.

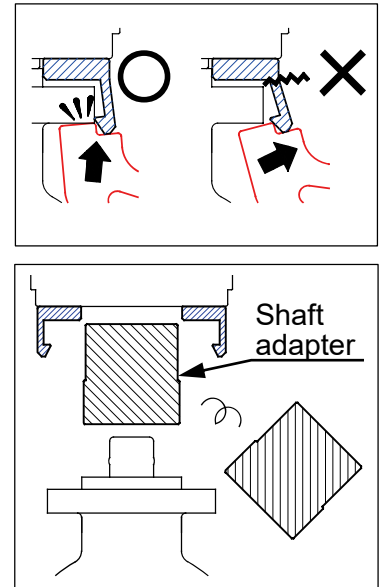

Necessary items

- Base plate removing jig (Optional items)



<Removal>

Procedure

- 1) Completely eliminate pressure in the pipe.
- 2) Close the master valve for operation air, and release air from the actuator.
- 3) Remove the air pipe.
- 4) Put the tip of the base plate removing jig at the center of the claw on one side of the base plate. (Refer to Fig. 17-1.)
- 5) Move the removing jig in a way that it pushes the claw of the base plate upward with the side of the valve as a fulcrum to release the hooking with the main body of the valve. (Refer to Fig. 17-2.)
- 6) For the other claw, perform the steps 4) to 5) to release the hooking with the main body of the valve.
- 7) When the hooking of the both claws is released, lift the actuator vertically to disconnect from the valve. (Refer to Fig. 17-3.)

Fig. 17-1

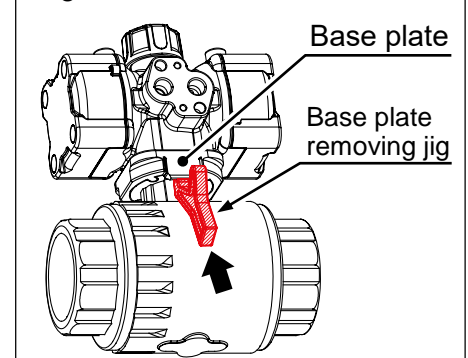

Fig. 17-2

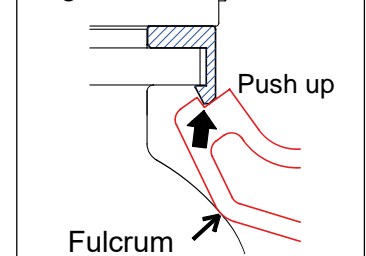
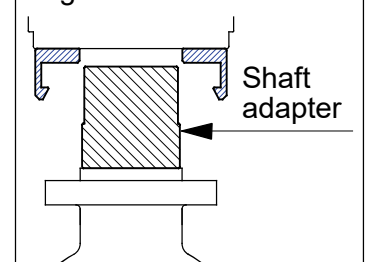

Fig. 17-3



<Attachment>

Procedure

- 1) Confirm that the opening display of the actuator and the directions of the valve stem and shaft adapter are correct.
- 2) Check the fitting position of the top flange of the valve and the base plate.
- 3) Push the base plate onto the valve until its claws firmly catch the top flange while checking visually.

18. Inspection items



Caution

- Perform periodic maintenance. (Leakage may develop due to temperature changes or over periods of prolonged storage, rest or operation.)

Portion to be inspected	Inspection item
Actuator	<ul style="list-style-type: none"> - Existence of rust and corrosion on the appearance. - Tightening condition of respective threaded portions. (Loose or not) - Existence of abnormality in opening and closing operating sounds. - Smooth opening and closing operation <ul style="list-style-type: none"> * Even if the valve is operated less frequently, confirm that it opens and closes smoothly at least once per 30 days. * It is unnecessary to supply oil to this actuator.
Base plate	<ul style="list-style-type: none"> - Mating condition of the base plate.(Loose or not)
Valve	<ul style="list-style-type: none"> - Existence of scratches, cracks, deformation, and discoloring. - Existence of leakage from the valve to the outside. - Existence of leakage when the fully closed.

19. Troubleshooting

Problem	Cause	Treatment
The spanner does not turn (or cannot rotate) during manual operation at double acting type.	Already fully open or fully shut.	Turn the spanner in the opposite direction.
	Air is supplied to the actuator.	Close the master valve for operation air, and open the bypass valve.
	Foreign matter is in the valve.	Replace the valve with a new one.
	Valve torque is increasing due to piping stress.	Remove the piping stress.
	The torque is increased by the influence (temperature, components, pressure) of fluid on the valve.	Check the service condition. (Refer to pages 5)
The valve does not operate by air operations.	The power source of the control panel is Turned off.	Turn on the power source.
	The solenoid valve is disconnected.	Check the connection again. (Refer to page 7 and 15)
	Air is not supplied to the solenoid valve.	Supply air to solenoid valve.
	The supply voltage to the solenoid valve is wrong.	Check voltage with a tester and set specified voltage.
	The voltage to the solenoid valve is low.	
	The bypass valve opens.	Close bypass valve by turning the bypass valve knob in a clockwise direction.
	The speed controller's knob is fully turned in a clockwise direction.	Turn speed controller's knob in a counterclockwise direction. (Refer to pages 18)
	Foreign matter is in the valve.	Replace the valve with a new one.
	Valve torque is increasing due to piping stress.	Remove the piping stress.
	The torque is increased by the influence (temperature, components, pressure) of fluid on the valve.	Check the service condition. (Refer to pages 5)
Fluid leaks from the valve even when the valve is closed fully.	The seat is worn.	Replace the valve with a new one.
	The seat and ball are scratched.	
	Foreign matter is in the valve.	Discharge the foreign matter from the valve by opening and closing the valve several times.
Fluid leaks from the valve.	The O-ring is scratched or worn.	Replace the valve with a new one.
	The O-ring is projected from the groove.	
	The sliding face or the fixed face of the O-ring is scratched or worm.	
The actuator operates, but the valve does not open or close.	The stem or the shaft adapter is broken.	Replace the valve or shaft adapter with a new one.
	The engagement between the stem and the ball is broken.	

20. How to inquire about defects or replacement

- ! - If you fail to remedy a defect even if you take measures against the defect or take corrective actions, or when a part needs to be replaced, check the information on the labels attached to the actuator and valve and contact the nearest sales office.

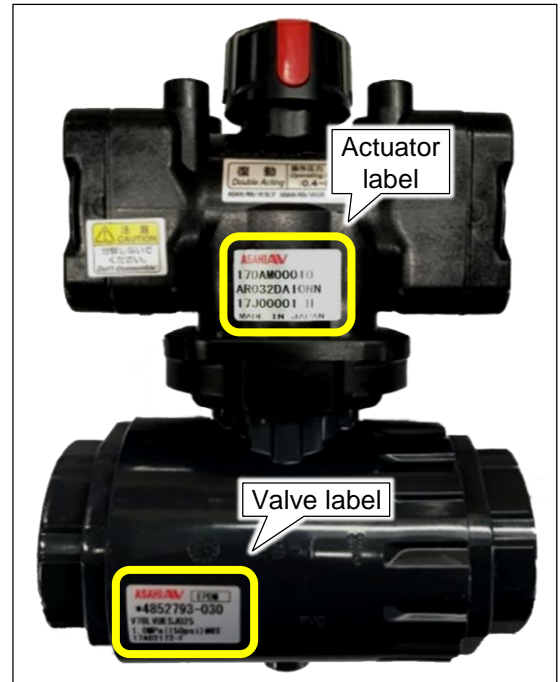

21. Handling of residual and waste materials

-  ! - Make sure to consult a waste treatment dealer for recommendations on the proper disposal of plastic valves. (Poisonous gas is generated when the valve is burned improperly.)

Compact Ball Valve Type27 Pneumatic Actuated Type AR

13-50mm ($\frac{3}{8}$ "-2")

ASAHI YUKIZAI CORPORATION



Distributor

<http://www.asahi-yukizai.co.jp/en/>