

Serial No.	H-A030-E-5
------------	------------

Rotary Damper Pneumatic Actuated Type TA

40mm(1 1/2")~600mm(24")

User's Manual

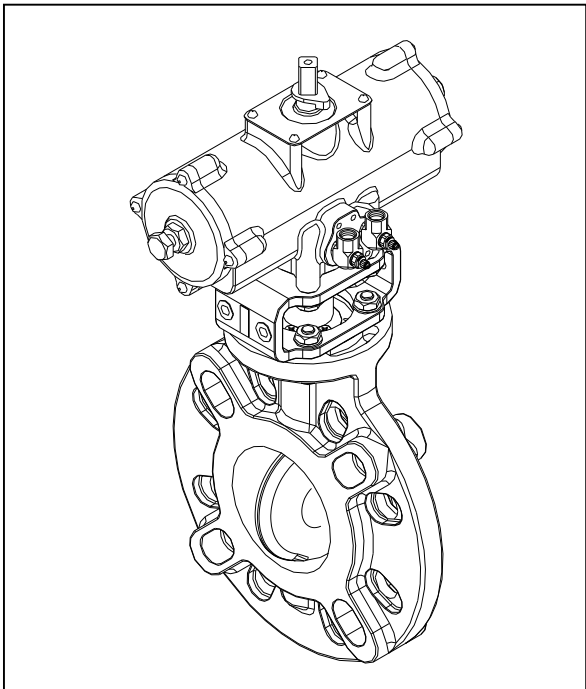



Contents



(1) Be sure to read the following warranty clauses of our product.....	1
(2) General operating instructions	2
(3) General instructions for transportation, unpacking and storage	3
(4) Name of parts	4
(5) Maximum working pressure vs. temperature	7
(6) Specifications of actuator	8
(7) Specifications of solenoid valve	9
(8) Specifications of limit switch	10
(9) Specifications of filter regulator	10
(10) Specifications of speed controller	11
(11) Installation procedure	12
(12) Support setting procedure	14
(13) Air piping procedure	15
(14) Connection of limit switch procedure	17
(15) Connection of solenoid valve procedure	18
(16) Operating procedure.....	19
Manual operating procedure	20
Automatic operating procedure	21
(17) Adjustment of opening / closing speed procedure	22
(18) Disassembling method for replacing parts	24
(19) stopper adjustment procedure	26
(20) Inspection items	27
(21) Troubleshooting	27
(22) Handling of residual and waste materials	28

This user's guide contains information important to the proper installation, maintenance and safe use of an ASahi AV Product. Please store this manual in an easily accessible location.

<Warning & Caution Signs>

 Warning	This symbol reminds the user to take caution due to the potential for serious injury or death.
 Caution	This symbol reminds the user to take caution due to the potential for damage to the valve if used in such a manner.

<Prohibited & Mandatory Action Signs>

	Prohibited: When operating the valve, this symbol indicates an action that should not be taken.
	Mandatory action: When operating the valve, this symbol indicates mandatory actions that must be adhered to.

(1) Be sure to read the following warranty clauses of our product

- Always observe the specifications of and the precautions and instructions on using our product.
- We always strive to improve product quality and reliability, but cannot guarantee perfection. Therefore, should you intend to use this product with any equipment or machinery that may pose the risk of serious or even fatal injury, or property damage, ensure an appropriate safety design or take other measures with sufficient consideration given to possible problems. We shall assume no responsibility for any inconvenience stemming from any action on your part without our written consent in the form of specifications or other documented approval.
- The related technical documents, operation manuals, and other documentation prescribe precautions on selecting, constructing, installing, operating, maintaining, and servicing our products. For details, consult with our nearest distributor or agent.
- Our product warranty extends for one and a half years after the product is shipped from our factory or one year after the product is installed, whichever comes first. Any product abnormality that occurs during the warranty period or which is reported to us will be investigated immediately to identify its cause. Should our product be deemed defective, we shall assume the responsibility to repair or replace it free of charge.
- Any repair or replacement needed after the warranty period ends shall be charged to the customer.
- The warranty does not cover the following cases:
 - (1) Using our product under any condition not covered by our defined scope of warranty.
 - (2) Failure to observe our defined precautions or instructions regarding the construction, installation, handling, maintenance, or servicing of our product.
 - (3) Any inconvenience caused by any product other than ours.
 - (4) Remodeling or otherwise modifying our product by anyone other than us.
 - (5) Using any part of our product for anything other than the intended use of the product.
 - (6) Any abnormality that occurs due to a natural disaster, accident, or other incident not stemming from something inside our product.

(2) General operating instructions



Warning



- Do not disassemble or modify the actuator.
(If disassembled forcible, internal parts may jump out and this is very dangerous.)
- Using a positive-pressure gas with our plastic piping may pose a dangerous condition due to the repellent force particular to compressible fluids even when the gas is under similar pressures used for liquids. Therefore, be sure to take the necessary safety precautions such as covering the piping with protective material. For inquiries, please contact us. For conducting a leak test on newly installed piping, be sure to check for leaks under water pressure. If absolutely necessary to use a gas in testing, please consult your nearest service station beforehand.



Caution



- Do not step on or apply excessive weight on valve. (It can be damaged.)
- Do not use AV valves in a place where they may become submerged in water.
- Do not use the valve in conditions where the fluid may have crystallized.
(The valve will not operate properly.)
- Keep the valve away from excessive heat or fire. (It can be damaged, or destroyed.)
- Always operate the valve within the pressure vs. temperature range.
(The valve can be damaged or deformed by operating beyond the allowable range.)
- Allow sufficient space for maintenance and inspection.
- Select a valve material that is compatible with the media. For chemical resistance information, refer to “CHEMICAL RESISTANCE ON ASAHI AV VALVE”.
(Some chemicals may damage incompatible valve materials.)
- Keep the valve out of direct sunlight, water and dust. Use cover to shield the valve.
(The valve will not operate properly.)
- Perform periodic maintenance. (Leakage may develop due to temperature changes or periods of prolonged storage, rest, or operation.)
- Set valve support on the valve.
- The AV valves must be used within the specifications specifically applicable to the product.
- If the actuator is used in an environment below 5°C temperature, its operating fluid must be free from the water and moisture contained in it because of possible problems due to the freeze.
- The operating fluid must be clean air filtered through a pertinent air filter.

(3) General instructions for transportation, unpacking and storage



Warning

- When suspending and supporting a valve, take care and do not stand under a suspended valve.



Caution

- This valve is not designed to handle impacts of any kind. Avoid throwing or dropping the valve.
- Avoid scratching the valve with any sharp object.
- Do not over-stack cardboard shipping boxes. Excessively stacked packages may collapse.
- Avoid contact with any coal tar creosote, insecticides, vermicides or paint. (These chemicals may cause damage to the valve.)
- When transporting a valve, do not carry it by the handle.
- Store products in their corrugated cardboard boxes. Avoid exposing products to direct sunlight, and store them indoors (at room temperature). Also avoid storing products in areas with excessive temperatures. (Corrugated cardboard packages become weaker as they become wet with water or other liquid. Take care in storage and handling.)
- After unpacking the products, check that they are defect-free and meet the specifications.

(4) Name of parts

40mm(1-1/2")-350mm(14")

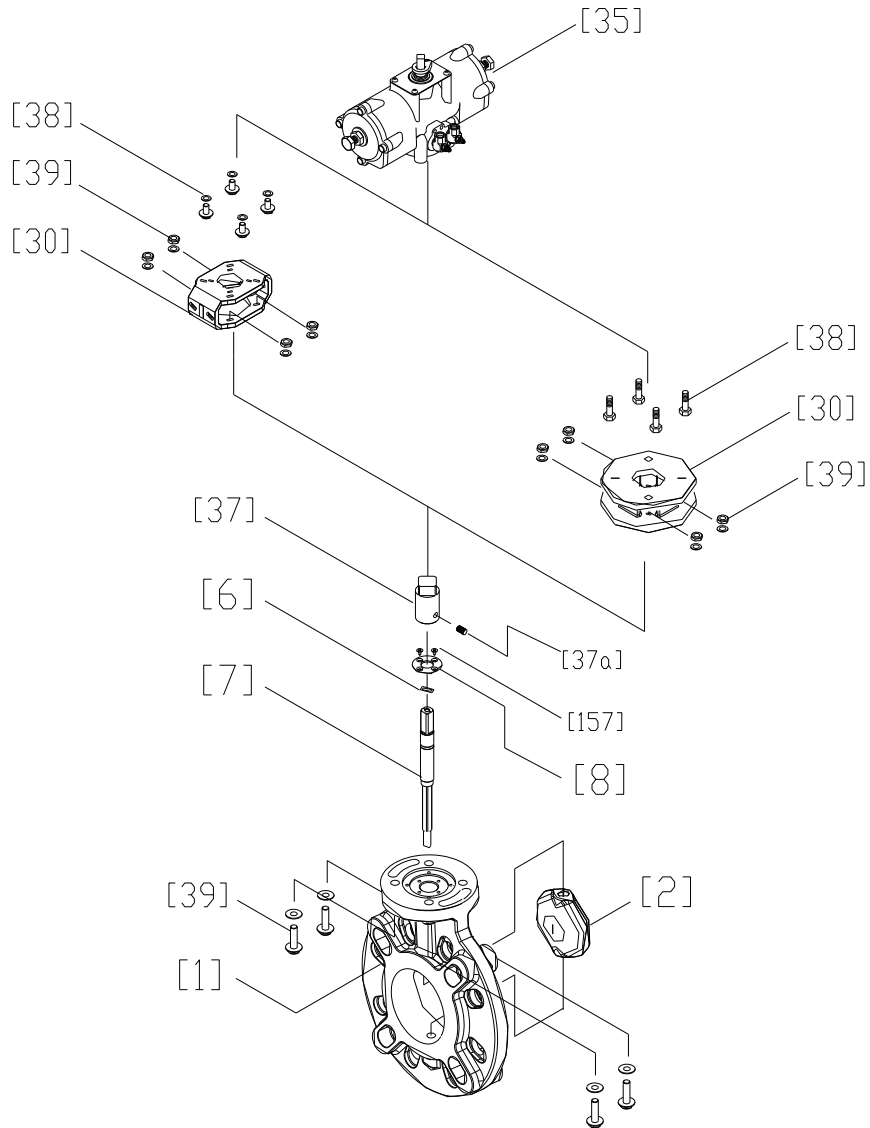

No.	DESCRIPTION	No.	DESCRIPTION	No.	DESCRIPTION
[1]	Body	[8]	Stem Holder (A)	[37a]	Screw (C)
[2]	Disc	[30]	Stand	[38]	Bolt (E)
[6]	O-ring (C)	[35]	Actuator	[39]	Bolt, Nut (A)
[7]	Stem	[37]	Joint (A)	[157]	Screw (F)

400mm(16")-600mm(24") Body material; PP

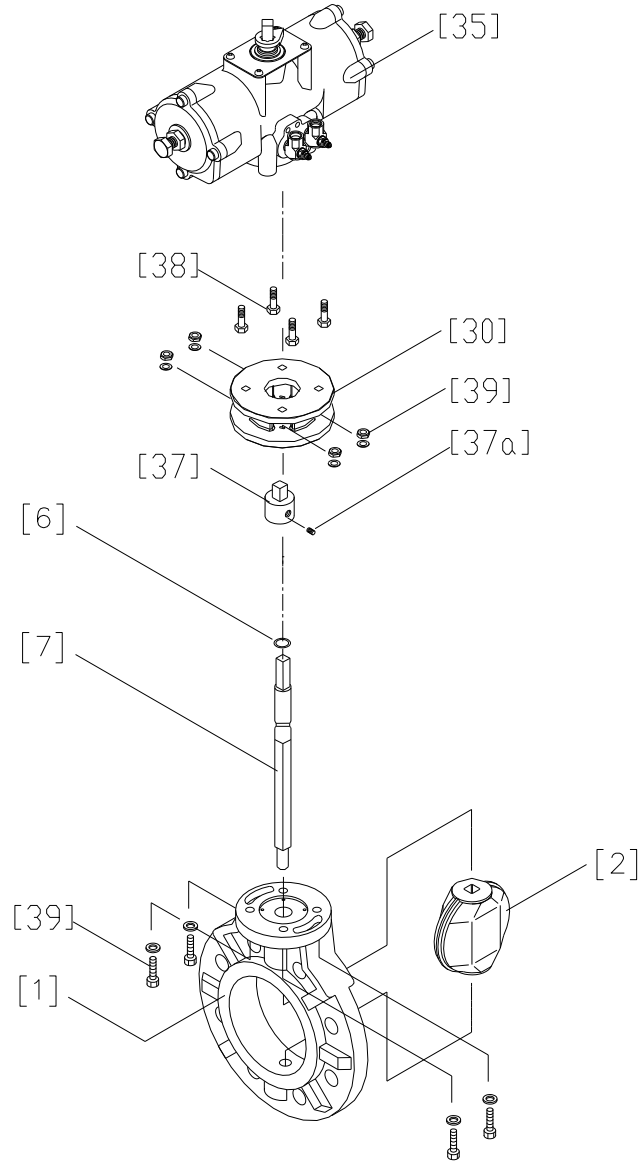

No.	DESCRIPTION	No.	DESCRIPTION	No.	DESCRIPTION
[1]	Body	[30]	Stand	[38]	Bolt (E)
[2]	Disc	[35]	Actuator	[39]	Bolt, Nut (A)
[6]	O ring (C)	[37]	Stem bush		
[7]	Stem	[37a]	Screw (C)		

40mm~600mm (Body material: PVDF)

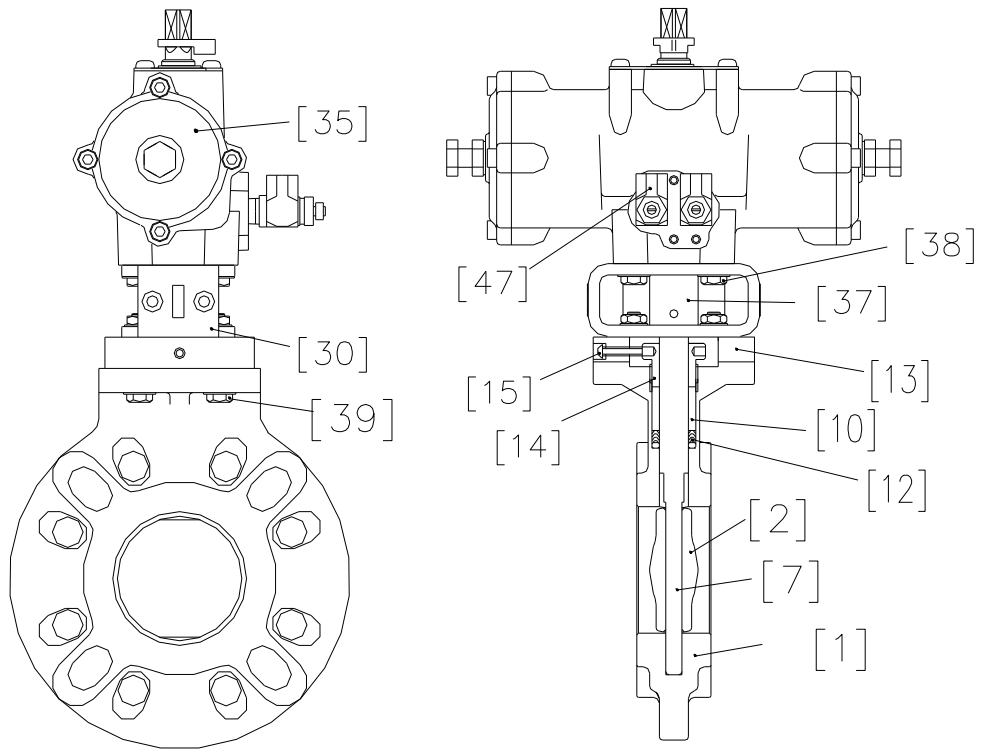

No.	DESCRIPTION	No.	DESCRIPTION	No.	DESCRIPTION
[1]	Body	[13]	Stand	[37]	Joint (A)
[2]	Disc	[14]	Actuator	[38]	Bolt (E)
[7]	Stem	[15]	Stem bush	[39]	Bolt, Nut (A)
[10]	Bush (A)	[30]	Screw (C)	[47]	Speed Controller
[12]	V-Packing	[35]	Actuator		

(5) Maximum working pressure vs. temperature

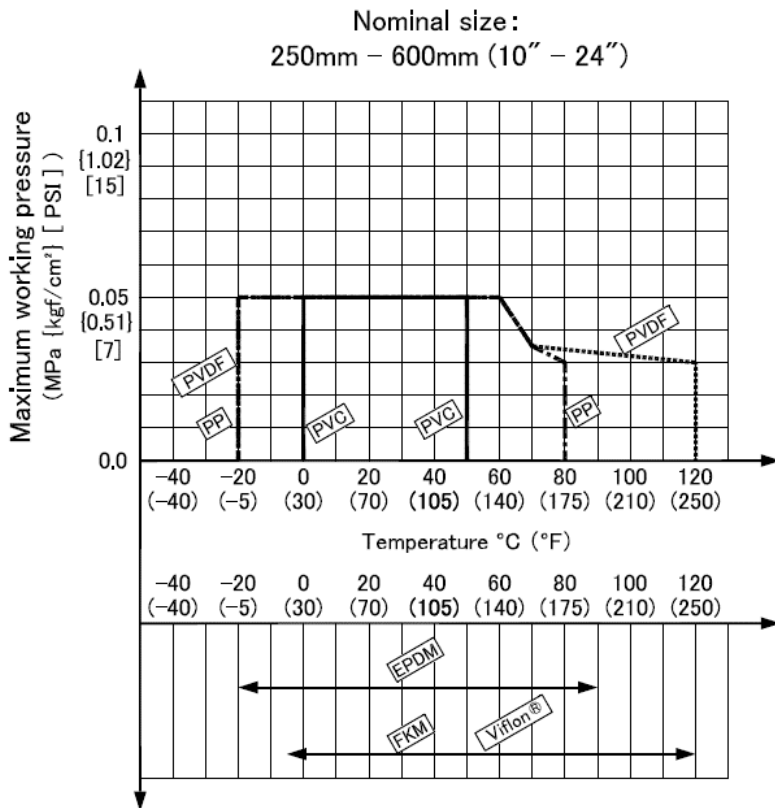
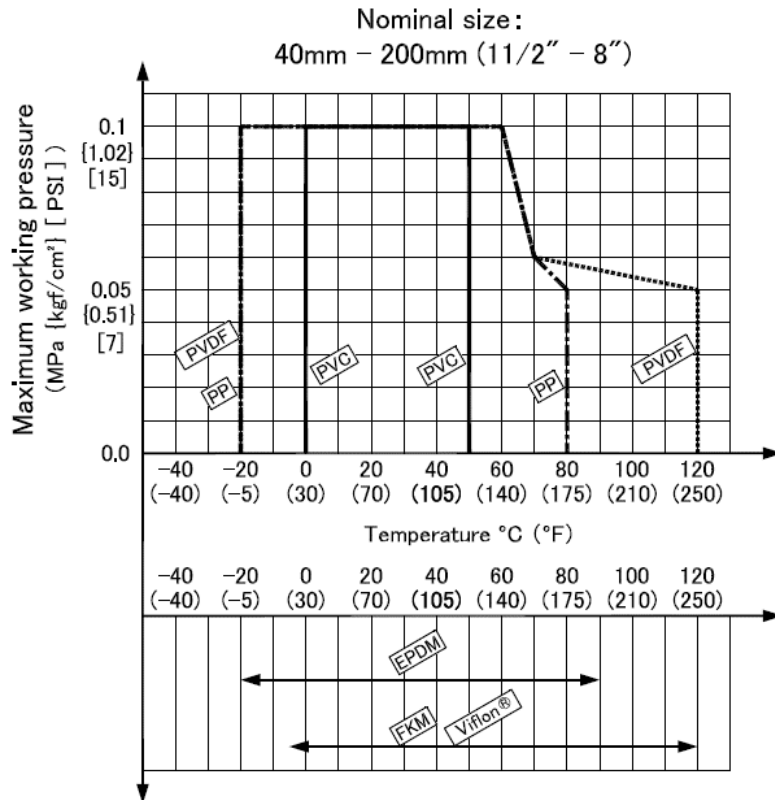

(6) Specification of actuator

Actuation	Nominal Size	Actuator Name	Angle Adjustment Range	Operating Pressure MPa [kgf/cm ²]	Air Consumption N l per 1 Open and Close (at 0.4MPa)	Air Supply Bore
Double Acting Type	40~100mm (1 1/2", 4")	TA2A-050D	±5°	0.4~0.7 {4.1~7.1}	0.9	Rc 1/4
	125, 150mm (4", 6")	TA2A-080D	±5°	0.4~0.7 {4.1~7.1}	3.2	Rc 1/4
	200~300mm (8"~12")	TA2A-100D	±5°	0.4~0.7 {4.1~7.1}	6.6	Rc 1/4
	350mm (14")	TA2A-125D	±5°	0.4~0.7 {4.1~7.1}	13.3	Rc 1/4
	400~600mm (16"~24")	TA2A-160D	±5°	0.4~0.7 {4.1~7.1}	27.1	Rc 1/4
Single Acting Type	40~100mm (1 1/2", 4")	TA2A-050R	±5°	0.4~0.7 {4.1~7.1}	1.7	Rc 1/4
	125, 150mm (4", 6")	TA2A-080R	±5°	0.4~0.7 {4.1~7.1}	6.1	Rc 1/4
	200~300mm (8"~12")	TA2A-100R	±5°	0.4~0.7 {4.1~7.1}	12.8	Rc 1/4
	350mm (14")	TA2A-125R	±5°	0.4~0.7 {4.1~7.1}	21.6	Rc 1/4
	400~600mm (16"~24")	TA2A-160R	±5°	0.4~0.7 {4.1~7.1}	42.7	Rc 1/4

(7) Specification of solenoid valve (option)

Actuation	Nom. Size	Type Code	Port Bore	Effective Cross Section Area	Power Consumption	Additional Function
All Type	40-600mm (1 1/2"-24")	4N3S102K-W□-G31193	Rc 1/4	10mm ² (0.016inch ²) or more	AC ; 6VA DC ; 5.5W	○Bypass valve built – in ○Silencer with needle valve attached (to be used as speed controller)

4N3S102K-W□-G31193



Specification	sign
AC100V 50/60Hz	1
AC110V 50/60Hz	(2)
AC200V 50/60Hz	3
AC220V 50/60Hz	(4)
DC24V	5
DC48V	(6)
DC100V	(7)
DC125V	(9)

Note: The number shown with () is not standard item.

Connection Diagram

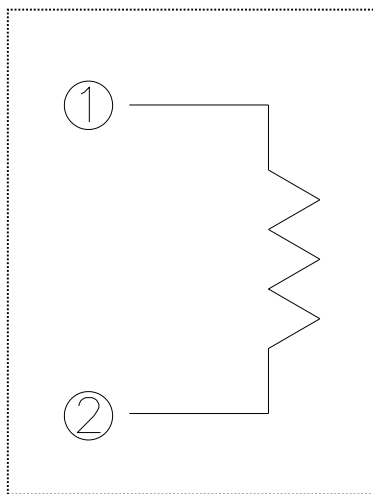

JIS Sign

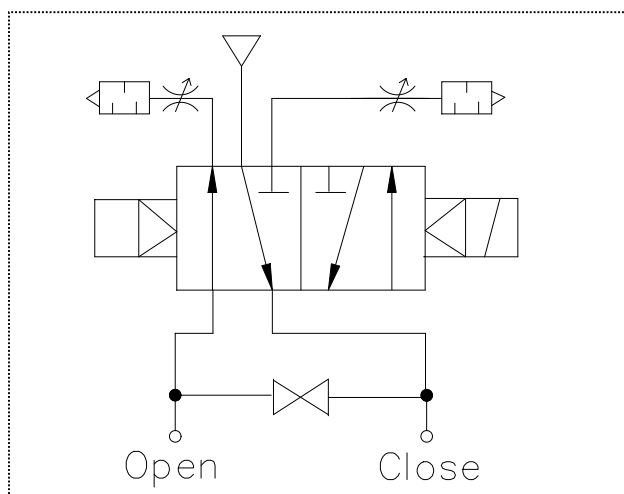

(8) Specification of limit switch (option)

Actuation	Nominal Size	Type Code	Protection Grade	Limit Switch Type
All Type	40-100mm (1 1/2"-4")	SB2-11	IP 65	V-112-1C24 (OMRON)
	125-300mm (5"-12")	SB2-16		
	350-600mm (14"-24")	SB2-22		

Limit Switch Rating

Rate Voltage (V)	Resistive Load (A)	Inductive Load (A)
AC125	11	7
AC250	11	7
DC125	0.5	0.1
DC250	0.25	0.04

Connection Diagram (At intermediate opening)

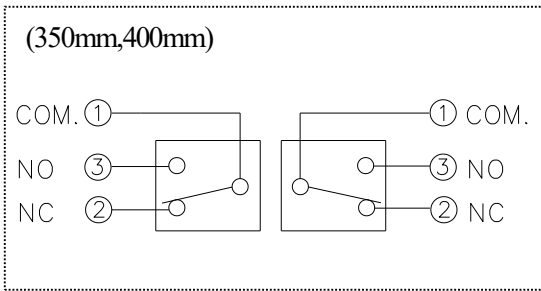
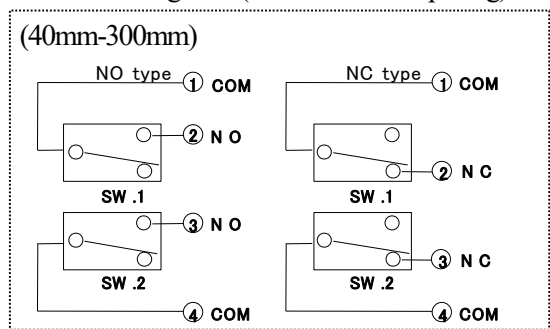

SW.1: Contact closes when valve is closed (double acting/air to open)
 Contact closes when valve is opened (air to shut)

SW2: Contact closes when valve is opened (double acting/air to open)
 The contact closes when the valve is closed (air to shut)

(9) Specification of filter regulator (option)

Actuation	Nom. Size	Type Code	Port Bore	Element degree of Filtration
All Type	40-600mm (1 1/2"-24")	ARU2-02-8A-G	Rc 1/4	5µm

JIS Sign

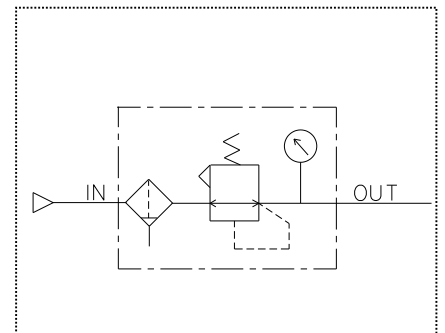

(10) Specification of speed controller (option)

Actuation	Nom. Size(mm)	Type Code	Port Bore	Effective Cross Section Area		Needle No. of Revolution
				Free Flow	Control Flow	
All Type	40-600mm (1 1/2"-24")	SC7-08A	Rc 1/4	11 mm ² (0.017inch ²)	8.3 mm ² (0.012inch ²)	8 turns

JIS Sign

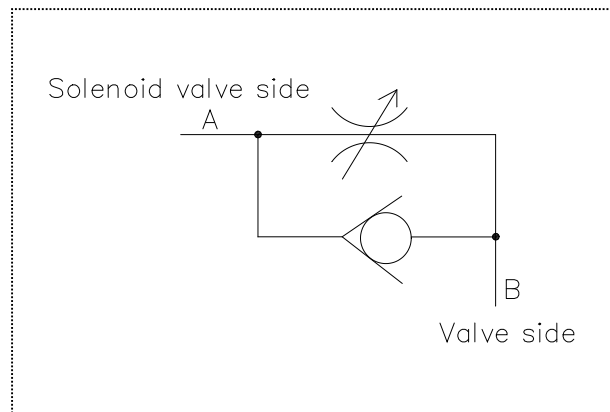

(11) Installation procedure

- Warning**
- ⚠️ - When suspending and supporting a valve, take care and do not stand under a suspended valve.
 - ⚠️ - Be sure to conduct a safety check on all hand and power tools to be used before beginning work.
 - ⚠️ - Wear protective gloves and safety goggles as fluid remain in the valve even if the pipeline is empty. (You may be injured.)
- Caution**
- ⚠️ - When installing a pipe support by means of a U-band or something similar, take care not to over-tighten. (Excessive force may damage the pipe.)
 - ⚠️ - Do not install the valve with the disc fully closed. (The disc may pinch into the seat, resulting in a high operating torque and preventing the valve from operating properly.)
 - ⚠️ - When installing pipes and valves, ensure that they are not subjected to tension, compression, bending, impact, or other excessive stress.
 - ⚠️ - Use flat faced flanges for connection to AV Valves.
 - ⚠️ - Ensure that the mating flanges are of the same standards.
 - ⚠️ - The gasket is unnecessary. (The seat carries out the role of the gasket.)

- Necessary items**
- Torque wrench
 - Bolt-Nut-Washer(Refer to page8 for the size.)
 - Spanner wrench
 - AV gasket

Procedure

- 1) Fully close the valve.
- 2) Set the AV gasket between the flanges.
- 3) Insert washers and bolts from the pipe side, insert washers and nuts from the valve side, then temporarily tighten them by hand.
(Threaded bolts are needed for JIS 10K the connection standard], 450mm~600mm [18"~24"])
- 4) Using a torque wrench, tighten the bolts and nuts gradually to the specified torque level in a diagonal manner (Refer to fig.1.)

Caution

- ⚠️ - Tighten the bolts and nuts gradually with a torque wrench to the specified torque level in a diagonal manner.

Fig. 1

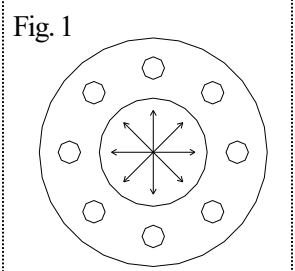

Recommended torque valve

Unit: N·m [kgf·cm] [lb·inch]

Nom. Size	40mm (1½")	50, 65mm (2"~2 1/2")	80, 100 mm (3", 4")	125, 150mm (5", 6")
Torque valve	20.0 {204} [177]	22.5 {230} {200}	30.0 {306} [266]	40.0 {408} [355]

Nom. Size	200,250mm (8", 10")	300, 350mm (12", 14")	400, 450mm (16", 18")	500, 600mm (20", 24")
Torque valve	55.0 {561} [488]	60.0 {612} [532]	80.0 {816} [710]	100.0 {1020} [887]

*These figures above show the specified torque value when the AV gasket used for 40mm(1½") to 350mm(14"). As for 400mm(16") or more, refer to the figures above just as the recommended torque value as they do not have AV gaskets.

Dimension of insert bolt A

Nom. size		Bolt			Nut	Washer
		d	L(mm)	S(mm)		
40mm	1½"	M16	more than 125mm	35	M16	16
50mm	2"		more than 125mm			
65mm	2½"		more than 130mm			
80mm	3"		more than 130mm			
100mm	4"		more than 145mm			
125mm	5"	M20	more than 165mm	40	M20	20
150mm	6"		more than 175mm			
200mm	8"		more than 190mm			
250mm	10"	M22	more than 220mm	40	M22	22
300mm	12"		more than 245mm			
350mm	14"	M24	more than 250mm	45	M24	24
400mm	16"		more than 300mm			
450mm	18"		more than 315mm			
500mm	20"	M30	more than 330mm	50	M30	30
600mm	24"		more than 375mm			

Dimension of insert bolt B

Nom. Size		Bolt (B)				Washer
		d ₁	L ₁ (mm)	S ₁ (mm)	S ₂ (mm)	
400mm	16"	M24	120	45	27	24
450mm	18"	M24	120 125	45	27	24
500mm	20"	M24	125 135	45	27	24
600mm	24"	M30	145 155	50	33	30

Bolt A

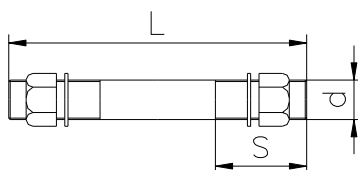

Bolt B

(valve side)

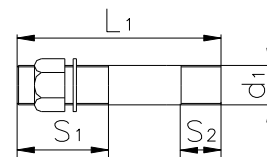



- The parallelism and axial misalignment of the flange surface should be under the values in the following table to prevent damage the valve.
(A failure to observe them can cause destruction due to stress application to the pipe)

Unit: mm (inch)

Nom. Size	Axial Misalignment	Parallelism (a-b)
40~80mm (1½"~3")	1.0mm(0.04")	0.8mm(0.03")
100~150mm (4"~6")	1.0mm(0.04")	1.0mm(0.04")
200~600mm (8"~24")	1.5mm(0.06")	1.0mm(0.04")

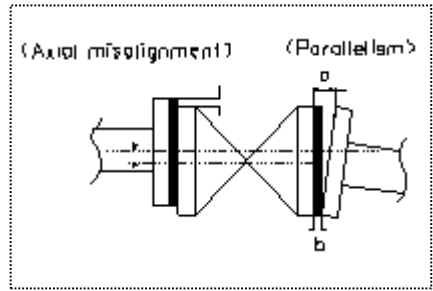

(12) Support setting procedure



- Set the valve support. (If not, the valve may be damaged because the actuator is heavy.)
Do not subject the valve to pump vibration. (The valve may be damaged.)

Necessary items

- Spanner Wrench
- U-Type Clamp (with bolt)
- Rubber Sheet

Level Installation

Set the stand under the valve.

Spread the rubber sheet on the pipe and secure pipe with U-type clamp.

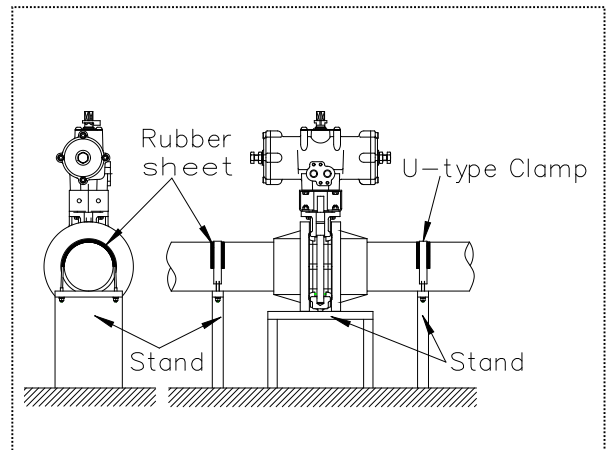

Perpendicular Installation

Spread the rubber sheet under the actuator and connection part of body and actuator.

Spread the rubber sheet on the pipe and secure pipe with U-type clamp.

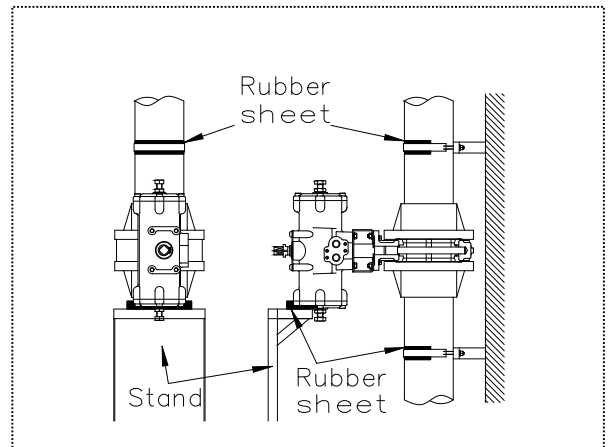

(13) Air piping procedure

< 1 > For a standard type and an attached speed controller type

Caution

- Do not remove a dust-proof cap provided to piping port before piping work starts.
- Avoid excessive tightening. (The threaded area of a pipe can be damaged.)
- Check the connection locations, air pipe sizes, and screw types with the approved drawings and other documents for the product. Then lay the air piping.
- The operating fluid must be clean air filtered through a pertinent air filter.
- If the actuator is used in an environment below 5°C temperature, its operating fluid must be free from the water and moisture contained in it because of possible problems due to the freeze.
- Steel pipes must always be of the plated.
- Before installing an actuator in pipeline, flash the inside of pipeline completely.
- Do not apply a sealant excessively lest it fall off in the pipeline when an actuator is piped.
- Threaded area of a pipe must be free from the sharp edges and burr.

Necessary items

- Spanner Wrench
- Seal Tape (If seal tape isn't used, leakage may be caused)
- Steel Pipe or Tube for Piping
- Joint for Steel Pipe or Tube

Procedure

- 1) Wind a seal tape onto the male thread of the joint with a blank about 3mm (0.12") (about 2 threads) left at the end.
- 2) Screw the joint in the piping female thread of the actuator by hand to the full.
- 3) Screw the joint one turn with a spanner wrench.
*Avoid excessive tightening.
(The valve can be damaged.)
- 4) Mount a steel pipe or a tube.

*The diagrams at left are without speed controllers, however, air piping procedure is the same way as above.

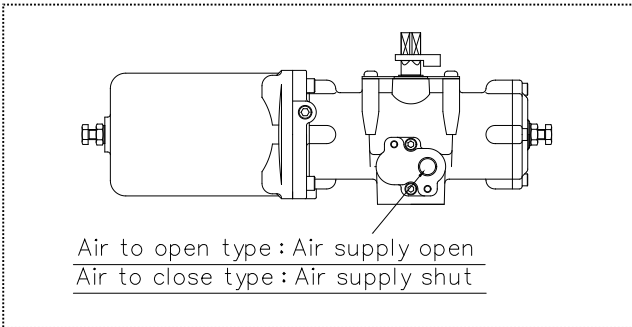
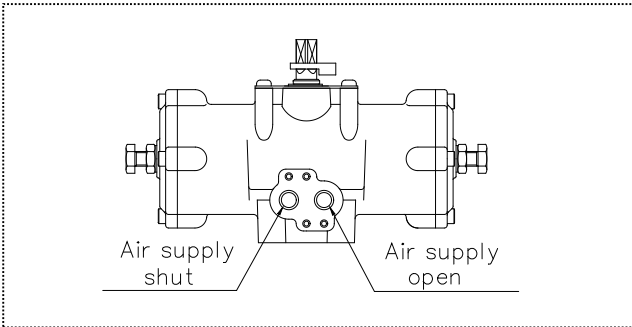

<2> For a valve with a solenoid valve and a pressure reducing valve with a filter regulator.

Caution

- Do not remove a dust-proof cap provided to piping port before piping work starts.
- Avoid excessive tightening. (The threaded area of a pipe can be damaged.)
- Steel pipes must always be of the plated.
- Before installing an actuator in pipeline, flash the inside of pipeline completely.
- Do not apply a sealant excessively lest it fall off in the pipeline when an actuator is piped.
- Threaded area of a pipe must be free from the sharp edges and burr.
- Open the drain periodically in order to exhaust the deposit.
- The equipment must be used at a pressure below the maximum operating pressure specified for the product.

Necessary items

- Spanner Wrench
- Seal Tape (If seal tape isn't used, leakage may be caused)
- Steel Pipe or Tube for Piping
- Joint for Steel Pipe or Tube

Procedure

- 1) Wind a seal tape onto the male screw of the joint with a blank about 3mm (0.12") (about 2 threads) left at the end.
- 2) Screw the joint in the piping female screw of the actuator by hand to the full.
- 3) Screw the joint one turn with a spanner wrench.
 - * Avoid excessive tightening. (The valve can be damaged.)
- 4) Mount a steel pipe or a tube.

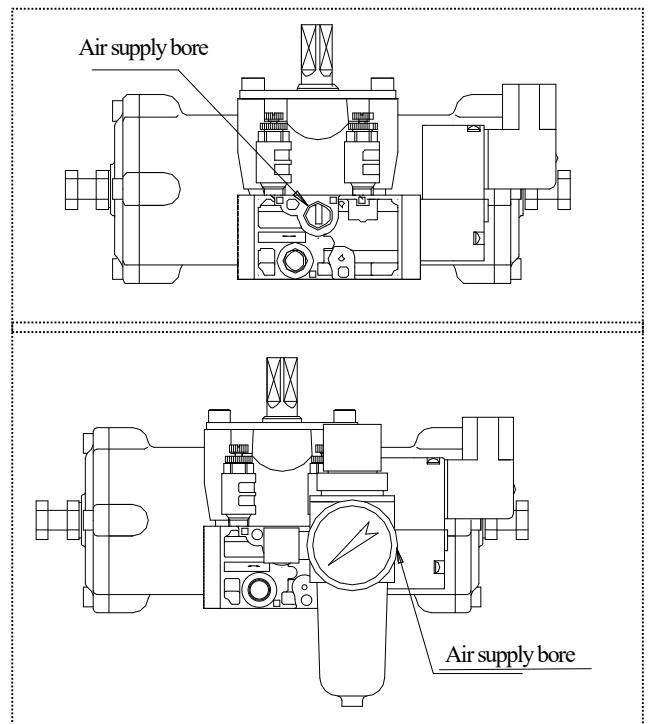

(14) Connection of limit switch procedure

Warning  - Shut down the power on the equipment before connecting wires. There are risks of electrical shock depending on the level of operating voltage.

Caution  - Be sure that the cover are put on during the operation.

-  - Connect the cables by using insulated sheathed crimping terminals in such a way as not to contact the cover or housing. (Contact of a crimping terminal with the cover may disable the cover from being closed or may cause a ground fault.)
- If you use the limit switch at 1mA-100mA or 5-30V, consult near Asahi dealer.
- Be sure that the terminal cover and body cover are put on during the operation.

Necessary items

- Screw Driver (+: Phillips)
- Screw Driver (-: Flat)
- Connector(G1/2)
- Wire Stripper

Procedure

- 1) Remove the indicator.
- 2) Remove the fixed screws from casing using screw driver (+).
* Don't be missing the o-ring of case end.
- 3) Turn to counter clockwise and remove the piping port protective cap.
- 4) Draw the cable through the connector.
- 5) Strip the cable with wire stripper.
- 6) Connect the cable to terminal board with a screw driver (-) in accordance page 10.
* Tighten the screws.
(Short circuit or shocks may occur.)
- 7) Tighten up the connector to fix the cable.
- 8) The screws must be tightened in turn after set the casing with screws driver (+)
* Be sure to set the o-ring when the casing is re-set.
(Short circuit or shocks may occur.)
- 9) Inset the indicator to the upper camshaft which must be set same direction of the seal's arrow.

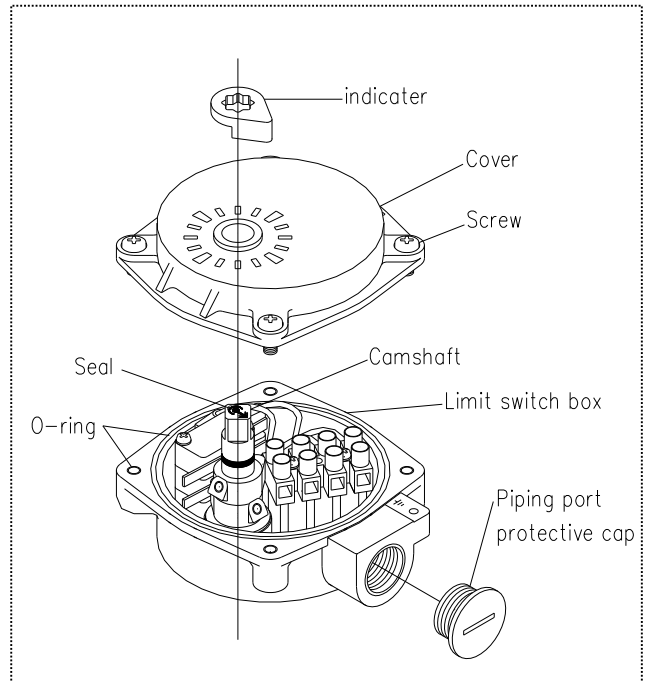

(15) Connection of solenoid valve procedure

 - Go after you surely interrupt a power supply when you do the installation of the terminal base line is combined.



 - Solenoid valve-A speed controller adjusts and fasten a lock nut by open ended spanners.

Necessary items

- Terminal Crimping tool
- Connector (G1/2)
- Screw Driver (+)
- Wire Dripper

Procedure

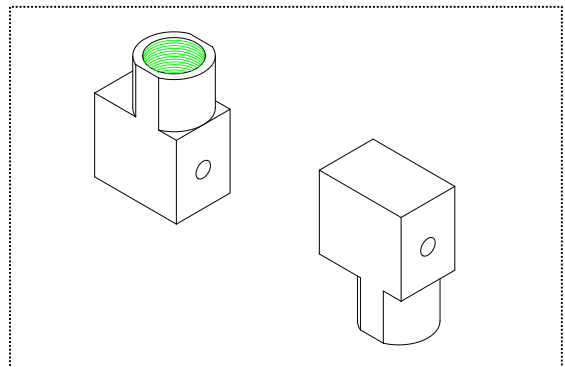
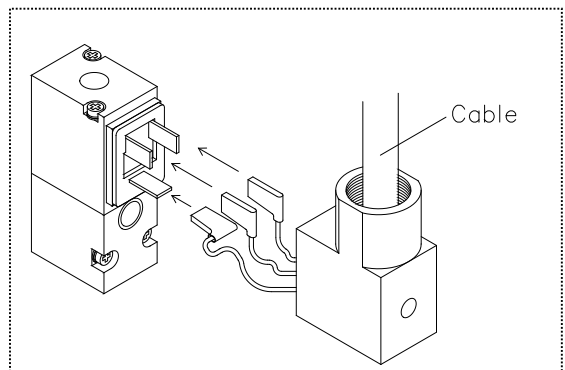
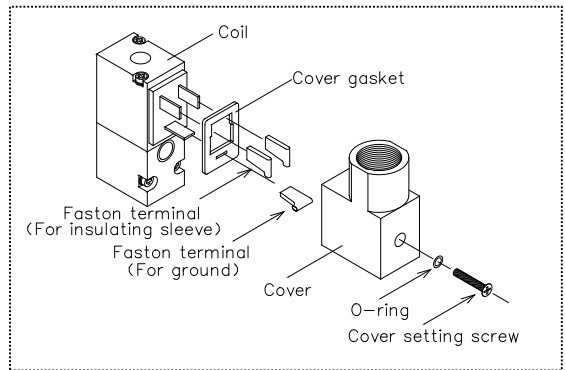
- 1) Loosen the hexagon socket head cap screws, and remove the cover.
 - * Don't loose O ring.
 - (Otherwise electric leaks or shocks may occur.)
- 2) Remove the Faston terminal inserted into coil side and the insulating sleeve.
 - * Insulating sleeve isn't attached in Faston terminal.
- 3) Draw the cable through the connector to the cover.
- 4) Strip the cable with wire stripper.
- 5) Draw the lead wire through the cover.
- 6) Install the Faston terminal on the lead wire with a terminal-crimping tool.
- 7) Insert the Faston terminal into the coil side. And fit the cover.
- 8) Tighten the cover setting screws to fix it.
 - (The cover can be set with the wire extraction opening turned upward or downward.)
- 9) Tighten the cable by connector.



(16) Operating procedure

Manual Operating Procedure

○ Double acting type



Caution



- Don't supply air during manual operation.
(When air is supplied during the manual operation, you may be injured.)



- In case of solenoid valve mounted, open the bypass valve to make pressure in the actuator atmospheric.
(It allows to operate manually.)

Necessary items

- Spanner wrench or lever handle (Option)

Procedure

- 1) Attach the manual handle (Option) or the spanner to the output shaft in the upper part of the actuator, and turn the handle 1-2 times between full open and full shut.
When the limit switch is attached, remove the cap, and use the shaft for the operation.

Right turn (clock wise) → Shut direction

Left turn (counter clock wise) → Open direction

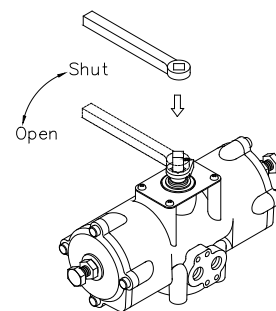
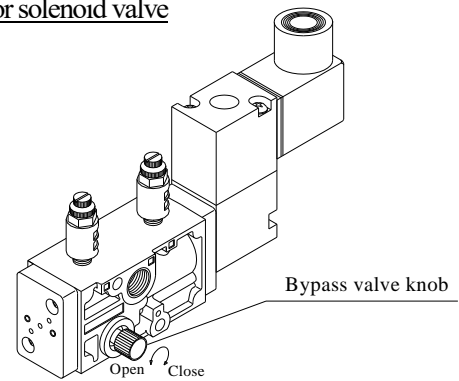

- 2) Attach the manual handle (Option) or the spanner to the output shaft in the upper part of the actuator.

For solenoid valve



Manual Operating Procedure

○ Single acting type

  - Only for the actuator which is the manual operation with groove.
Caution

Necessary items
● Spanner Wrench

Procedure

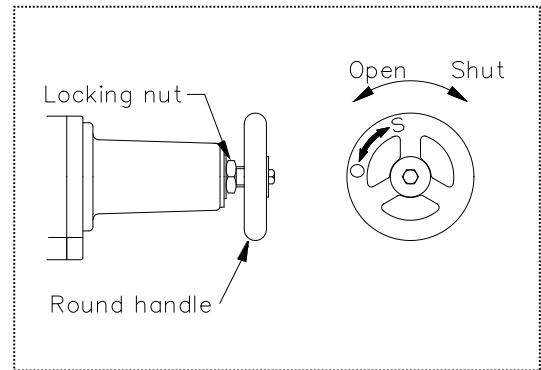

- 1) Loosen the locking nut with a spanner.
- 2) Turn the round handle for manual operation 1-2 times between full open and full shut.

Rotational direction of round handle	Air to open type	Air to close type
Clockwise	Shut	Open
C-Clockwise	Open	Shut





Nominal size	40 - 100mm (1 1/2" - 4")	125, 150mm (5", 6")	200 - 300mm (8" - 12")	350mm (14")	400 - 600mm (16" - 24")
Number of turns of the handle	About 24	About 27	About 28	About 36	About 38

- 3) Turn right the round handle to the full open or full shut.

  - Do not turn the handle forcibly at the full open or shut. (Otherwise the valve may be damaged.)
Caution

- 4) Tighten the locking nut with a spanner wrench.

Automatic (Air) Operating Procedure

  - The AV valves must be used within the specifications specifically applicable to the product.
Caution

Procedure

- 1) Supply air to the air supply opening.
- 2) Check to ensure that the valve indicating direction and the operating direction agree with each other.
- 3) Stop supplying air.

<For the solenoid valve >

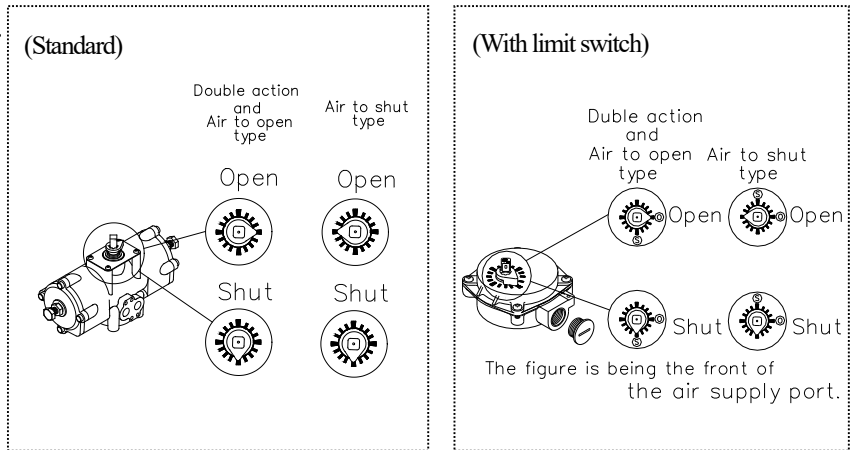

Procedure

- 1) Supply the air to the solenoid valve.
- 2) Push the button with a finger, and confirm the action mode shown in the following table.
- 3) Apply regular rated voltage to the solenoid valve, and confirm the action mode shown in the following table.
- 4) Turn off the solenoid valve

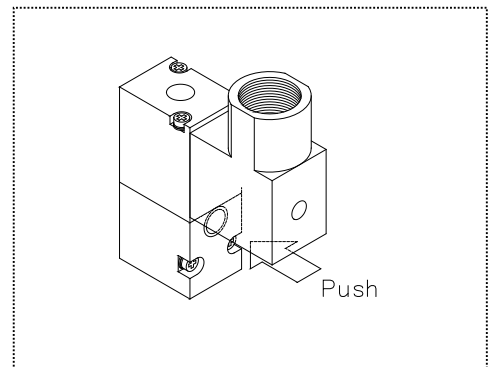

Push button	Current	Double action	Single action	
			Air to open	Air to close
Pushed	On	Open	Shut	
Not pushed	Off	Shut	Open	

(17) Adjustment of opening / closing speed procedure



Caution

- Solenoid valve-A speed controller adjusts and fasten a lock nut by open ended spanners.

○ Double acting type

Necessary items

- Spanner Wrench

Procedure

- 1) Turn right the adjustment knob of the solenoid valve fully.
 ※ Avoid excessive tightening.
 (The speed controller can be damaged.)
- 2) Supply the air to the solenoid valve.
- 3) Apply regular rated voltage to solenoid valve, and turn left the open side adjustment knob little by little.
- 4) Turn off the solenoid valve, and turn left the close side adjustment knob little by little.
- 5) Repeat item 3), 4) to adjust the opening / closing speed required.
- 6) When the adjustment is finished, fix the adjustment knob with locking nuts.
 ※ Avoid excessive tightening.
 (The locking nut can be damaged.)

For Double action type with solenoid valve

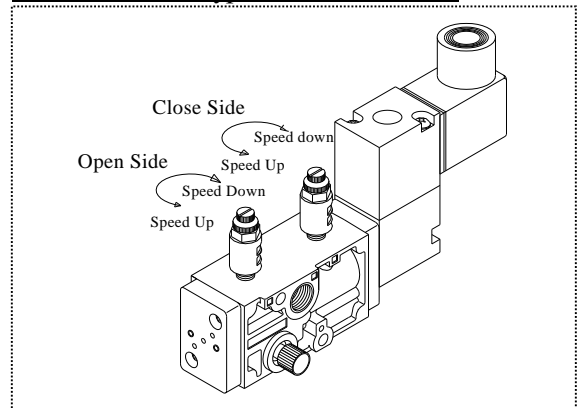

For Double action type with speed controller

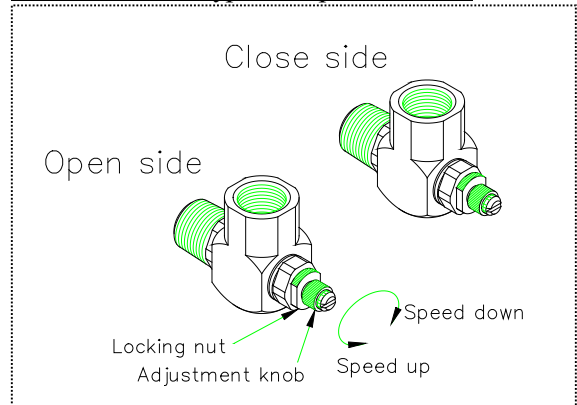

○ Single acting type

Necessary items

- Spanner Wrench

The actuation type changes the speed-adjustable direction.

Single action	Opening speed	Closing speed
Air to open type	Not adjustable	Adjustable
Air to close type	Adjustable	Not adjustable

Procedure

- 1) Turn right the adjustment knob of the solenoid valve fully.
※ Avoid excessive tightening.
(The speed controller can be damaged.)
- 2) Supply the air to the solenoid valve.
- 3) Apply regular rated voltage to solenoid valve, and turn left the open side adjustment knob little by little.
- 4) Turn off the solenoid valve, and turn left the close side adjustment knob little by little.
- 5) Repeat item 3), 4) to adjust the opening / closing speed required.
- 6) When the adjustment is finished, fix the adjustment knob with locking nuts.
※ Avoid excessive tightening.
(The locking nut can be damaged.)

For Single action type with solenoid valve

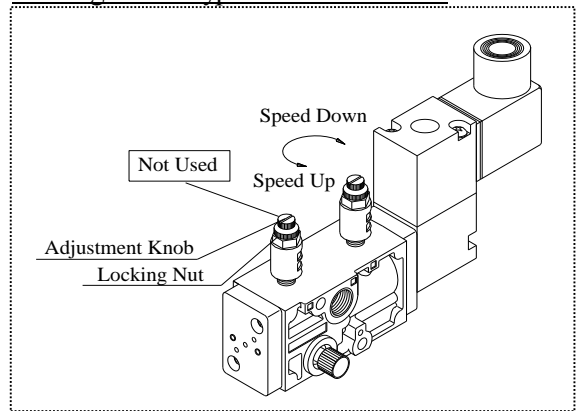

For Single action type with speed controller

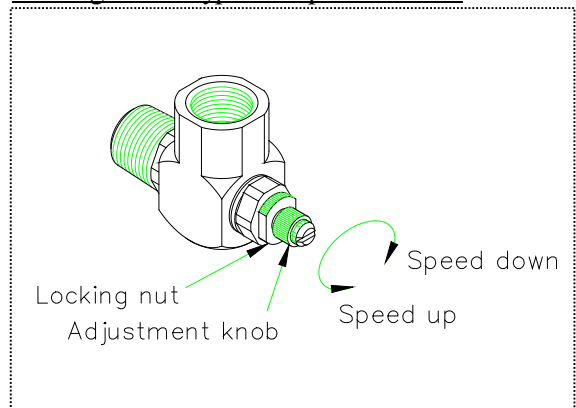

(18) Disassembling method for replacing parts



Caution

- Wear protective gloves and safety goggles as fluid remain in the valve even if the pipeline is empty. (You may be injured.)
- When installing pipes and valves, ensure that they are not subjected to tension, compression, bending, impact, or other excessive stress.
- Do not change or replace valve parts under line pressure.

Necessary items

- Jack
- Pipe
- Plate
- Allen Wrench
- Thrust Bearing
- Pliers
- Protective Gloves
- Safety Goggles

Disassembly Procedure

- 1) Completely discharge fluid from pipes.
- 2) Fully shut the valve by the air-operation or manual operation.
- 3) Turn off the power source.
- 4) Leave the valve slightly opened with a spanner wrench.
- 5) Loosen the insert bolts and remove them.
- 6) Remove the body part from piping system.
- 7) Loosen the bolt-nut (E)[38] or the bolt (K)[39], and remove the actuator [35] from the body [1].
*As for 40mm~350mm (1½”~14”), remove the stem retainer (A)[8] with screwdriver(+).
- 8) As for 40mm~100mm (1½”~4”), pull out the stem [7] by pliers or hand. As for 125mm~600mm (5”~24”), attach jack, thrust bearing, plate, and pipe to the valve, and thread the jack into the stem [7]. Remove the stem [7] from the jack.
- 9) Remove the O ring (C) [6].
- 10) Fully open the disc [2].
- 11) Remove the disc [2] from the body [1].

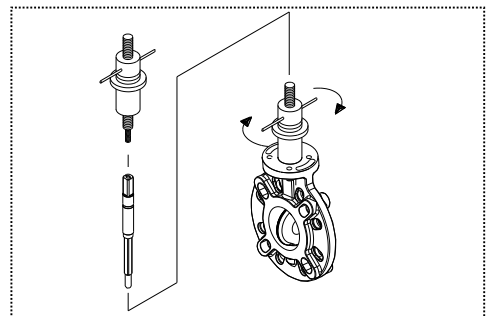
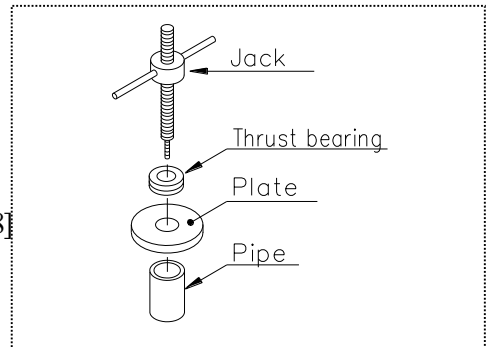
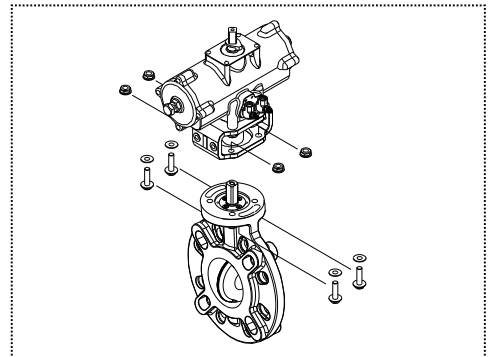

Assembly Procedure

- 1) Before starting assembly, silicone grease (equivalent to Toray Silicone HVG) should be spread on the disc O ring (C) [6].
- 2) The procedure of the assembly is the reverse of its disassembly from the item 11) on page 25.
- 3) Check to ensure that travel indicator shows correct position of the disc [2].
- 4) Fully open or close the valve by air operation. (Refer to page 22)
* In case that the travel indicator shows incorrect position of, turn off the power source and remove the cover of the actuator with a spanner wrench, then adjust the travel indicator.

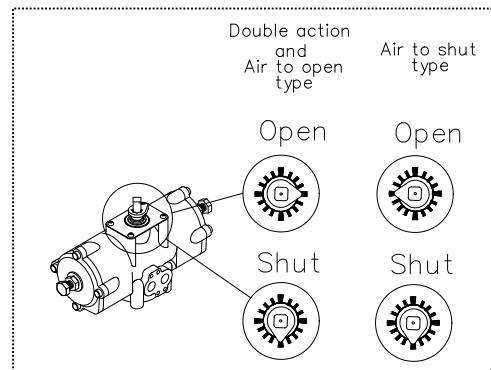
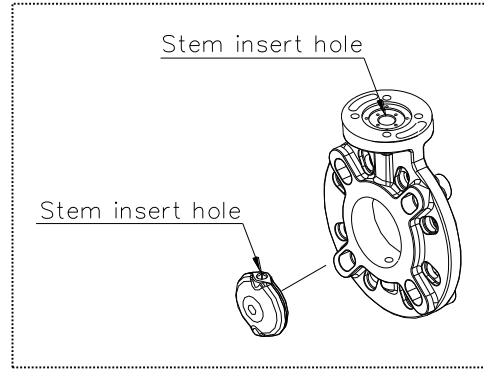

(19) Stopper adjustment procedure

- Caution**
- ⚠️ - Don't supply air during adjusting stopper.
(When air is supplied during adjusting stopper, you may be injured.)
 - 🚫 - Don't damage the seal washer. (Otherwise air may leak.)
 - ❗ - Avoid excessive tightening. (Otherwise air may leak.)

Necessary items

- Spanner Wrench
- Allen Wrench

Procedure

- 1) Stop supplying air, and open the bypass valve to exhaust the air in actuator.
- 2) Attach the spanner wrench or the hexagon wrench to stopper. And loose slowly the rocking nut with the spanner wrench.
- 3) Turn the stopper with the spanner or the allen wrench to adjusting direction.

Opening degree

Direction	Clock wise	Counter clock wise
Open side	Smaller	Larger
Close side	Larger	Smaller

- 4) Close the bypass valve, and supply the air to the actuator. Operate the valve with air to make sure that opening degree is adjusted correctly. Otherwise repeat item 1),2),3),4) to adjust opening degree.

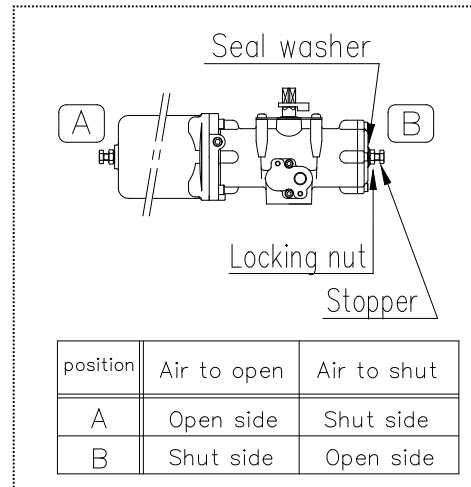
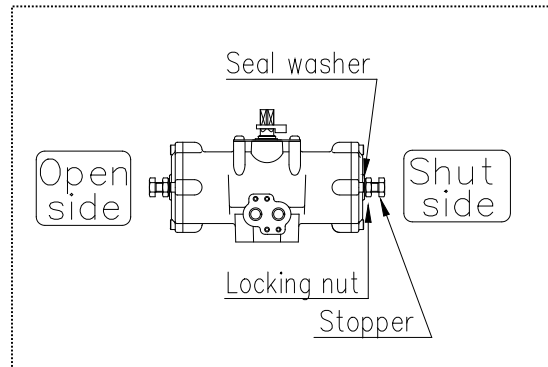

(20) Inspection items



Caution

! - Perform periodic maintenance. (Leakage may develop due to temperature changes or over periods of prolonged storage, rest or operation.)

○ Periodically inspect and maintain the AV valve in accordance with the decided schedule.



Portion to be inspected	Inspection item
Actuator	<ul style="list-style-type: none"> ● Existence of rust, peeling of paint, and dirt in inspection hole of valve travel indicator. ● Tightening condition of respective threaded portions. (Loose or not) ● Existence of abnormality in opening and closing operating sounds. ● Smooth operation of manual handle.
Note :	It is unnecessary to supply oil to this actuator.
Valve	<ul style="list-style-type: none"> ● Existence of scratches, cracks, deformation, and discoloring. ● Existence of leakage from the valve to the outside. ● Existence of leakage when the valve is opened fully at right or left.

(21) Troubleshooting

Problem	Cause	Treatment
The handle is not (can't be) turned when the valve is operated manually.	The valve has already been opened fully.	Turn the handle in the reverse direction.
	The air is supplied to actuator.	Shut the main valve, and open the solenoid valve.
	Foreign matter is in the valve.	Disassemble the valve to remove foreign matter. (Refer to page 13)
	The torque of the valve is increased by the piping stress.	Remove the piping stress.
	The torque is increased by the influence (temperature, components, pressure) of fluid on the valve.	Check service condition. (Refer to page 8)
The valve does not operate by air operations	The power source of the control panel is turned off.	Turn on the power source.
	The solenoid valve is disconnected.	Check the connection again.
	The supply voltage to the solenoid valve is wrong.	Check voltage with a tester and set specified voltage.
	The supply voltage to the solenoid valve is low.	
	The air is not supplied to actuator.	Open the main valve, and close the solenoid valve.
	The bypass valve is opened.	Close the bypass valve to turn the bypass valve knob light.

Problem	Cause	Treatment
The valve does not operate by air operations	Adjustment knob of speed controller is turned full light.	Turn the adjustment knob left.
	Foreign matter is in the valve.	Disassemble the valve to remove foreign matter. (Refer to page 13)
	The torque of the valve is increased by the piping stress.	Remove the piping stress.
	The torque is increased by the influence (temperature, components, pressure) of fluid on the valve.	Check service condition. (Refer to page 8)
The actuator operates, but the valve is not opened or close.	The stem or the joint is broken.	Replace the stem or the joint with a new one.
	The engagement between the stem and the ball is broken.	Replace the engagement with a new one.

(22) Handling of residual and waste materials



 - Make sure to consult a waste treatment dealer for recommendations on the proper disposal of plastic valves. (Poisonous gas is generated when the valve is burned improperly.)

**Rotary Damper
Pneumatic Actuated Type TA
(40mm~600mm)**

[Automatic Valve]

ASAHI YUKIZAI CORPORATION

Distributor

<http://www.asahi-yukizai.co.jp/en/>

Information in this manual is subject to change without notice.

2020.2