

Serial No.	H-V063-E-10
------------	-------------

Self Control Valves

- Pressure Reducing Type (V182, V82)
- Pressure Relief Type (V185)
- Pressure Retaining Type (V186)

Contents

1. Be sure to read the following warranty clauses of our product	1
2. General operating instructions	2
3. General instructions for transportation, unpacking and storage	2
4. Name of parts	3
5. Product functions and specifications	5
6. Maximum working pressure vs. temperature	6
7. Valve flow characteristic	7
Pressure reducing type	7
Pressure relief & retaining type	8
8. Installation procedure	9
Flanged end	10
Threaded end	11
Socket end	12
9. Adjustment procedure for working pressure	13
10. Disassembling method for replacing parts	14
11. Inspection items	15
12. Troubleshooting	16
13. Handling of residual and waste materials	16



User's Manual





This user's guide contains very important information for the proper installation, maintenance and safe use of an ASAHI AV Product.

Please store this manual in an easily accessible location.

<Warning & Caution Signs>

 Warning	This symbol reminds the user to take caution due to the potential for serious injury or death.
 Caution	This symbol reminds the user to take caution due to the potential for damage to the valve if used in such a manner.

<Prohibited & Mandatory Action Signs>







	Prohibited: When operating the valve, this symbol indicates an action that should not be taken.
	Mandatory action: When operating the valve, this symbol indicates mandatory actions that must be adhered to.

1. Be sure to read the following warranty clauses of our product





- Always observe the specifications of and the precautions and instructions on using our product.
- We always strive to improve product quality and reliability, but cannot guarantee perfection. Therefore, should you intend to use this product with any equipment or machinery that may pose the risk of serious or even fatal injury, or property damage, ensure an appropriate safety design or take other measures with sufficient consideration given to possible problems. We shall assume no responsibility for any inconvenience stemming from any action on your part without our written consent in the form of specifications or other documented approval.
- The related technical documents, operation manuals, and other documentation prescribe precautions on selecting, constructing, installing, operating, maintaining, and servicing our products. For details, consult with our nearest distributor or agent.
- Our product warranty extends for one and a half years after the product is shipped from our factory or one year after the product is installed, whichever comes first. Any product abnormality that occurs during the warranty period or which is reported to us will be investigated immediately to identify its cause. Should our product be deemed defective, we shall assume the responsibility to repair or replace it free of charge.
- Any repair or replacement needed after the warranty period ends shall be charged to the customer.
- The warranty does not cover the following cases:
 - (1) Using our product under any condition not covered by our defined scope of warranty.
 - (2) Failure to observe our defined precautions or instructions regarding the construction, installation, handling, maintenance, or servicing of our product.
 - (3) Any inconvenience caused by any product other than ours.
 - (4) Remodeling or otherwise modifying our product by anyone other than us.
 - (5) Using any part of our product for anything other than the intended use of the product.
 - (6) Any abnormality that occurs due to a natural disaster, accident, or other incident not stemming from something inside our product.

* Note that damage induced by a defect of our product is not covered by warranty.
- This guarantee applies to the use of our product only in Japan. If it is used overseas, please inquire with us separately.

2. General operating instructions

- 

Warning
 – Using a positive-pressure gas with our plastic piping may pose a dangerous condition due to the repellent force particular to compressible fluids even when the gas is under similar pressures used for liquids. Therefore, be sure to take the necessary safety precautions such as covering the piping with protective material. For inquiries, please contact us. For conducting a leak test on newly installed piping, be sure to check for leaks under water pressure. If absolutely necessary to use a gas in testing, please consult your nearest service station beforehand.
- 

Caution
 – Do not step on or apply excessive weight on valve. (It can be damaged.)
 – Keep the valve away from excessive heat or fire. (It can be damaged, or destroyed.)
- 

Caution
 – Always operate the valve within the pressure vs. temperature range.(The valve can be damaged or deformed by operating beyond the allowable range.)
 – Do not use the valve to fluid containing slurry. (The valve will not operate properly.)
 – Allow sufficient space for maintenance and inspection.
 – Select a valve material that is compatible with the media. For chemical resistance information, refer to “CHEMICAL RESISTANCE ON ASAHI AV VALVE”.(Some chemicals may damage incompatible valve materials.)
 – Do not use the valve in conditions where the fluid may have crystallized.(The valve will not operate properly.)
 – Keep the valve out of direct sunlight, water and dust. Use cover to shield the valve.(The valve will not operate properly.)
 – Perform periodic maintenance. (Leakage may develop due to temperature changes or over periods of prolonged storage, rest or operation.)

3. General instructions for transportation, unpacking and storage

- 

Warning
 – When suspending and supporting a valve, take care and do not stand under a suspended valve.
- 

Caution
 – This valve is not designed to handle impacts of any kind. Avoid throwing or dropping the valve.
 – Avoid scratching the valve with any sharp object.
 – Do not over-stack cardboard shipping boxes. Excessively stacked packages may collapse.
 – Avoid contact with any coal tar creosote, insecticides, vermicides or paint. (These chemicals may cause damage to the valve.)
 – When transporting a valve, do not carry it by the handle.
- 
 – Store products in their corrugated cardboard boxes. Avoid exposing products to direct sunlight, and store them indoors (at room temperature). Also avoid storing products in areas with excessive temperatures. (Corrugated cardboard packages become weaker as they become wet with water or other liquid. Take care in storage and handling.)
 – After unpacking the products, check that they are defect-free and meet the specifications.

4. Name of parts

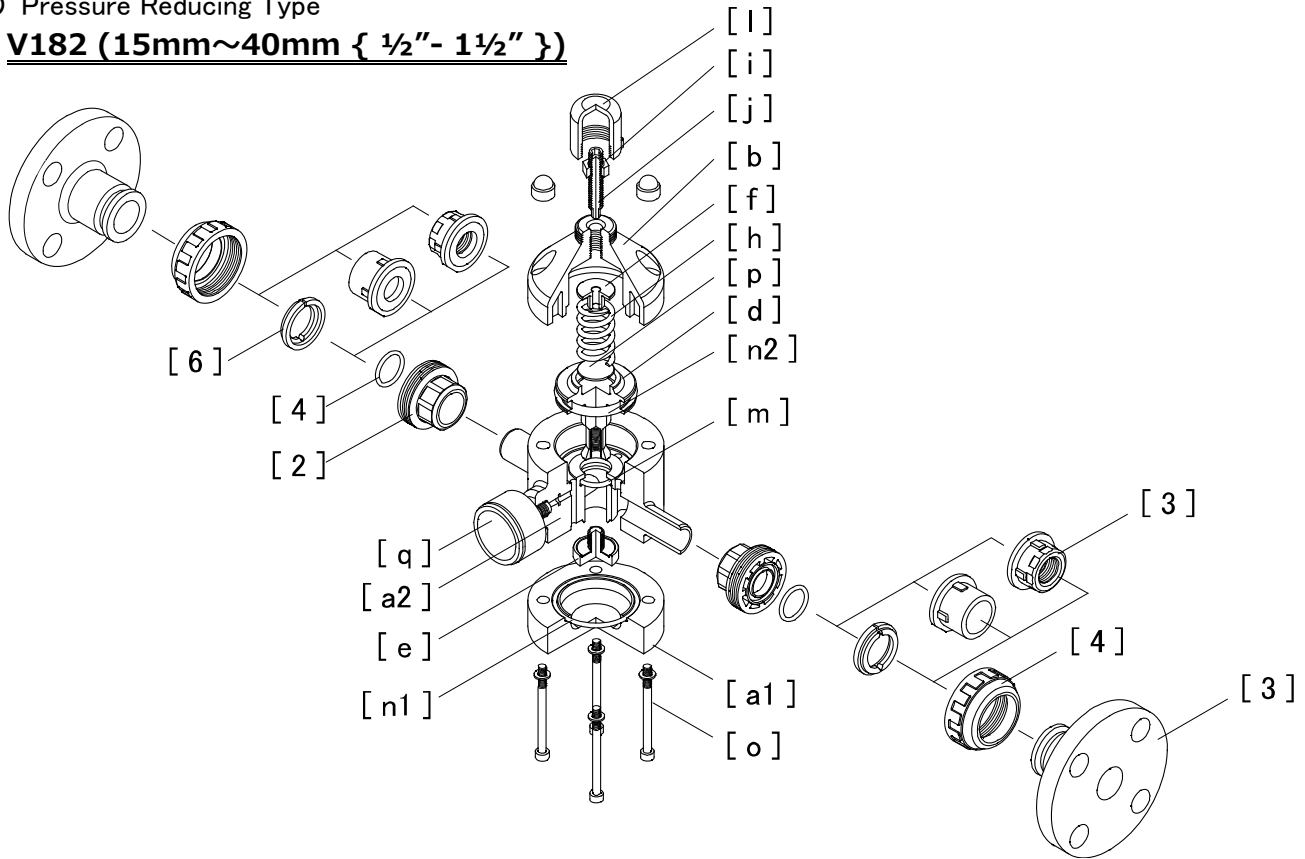
○ Pressure Reducing Type

V182 (15mm~40mm { 1/2" - 1 1/2" })



V82 (50mm {2"} ; PTFE spec only)

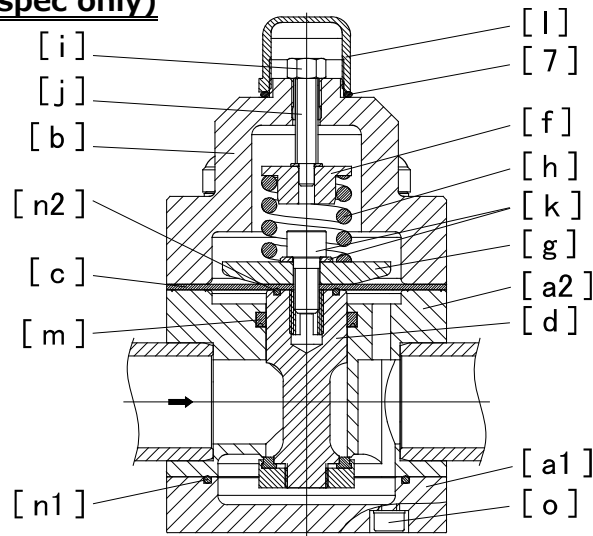

No.	Description	No.	Description	No.	Description	No.	Description
[a1]	Body (Bottom)	[g]	Compressor*1	[n1]	O-Ring (A)	[4]	Union nut
[a2]	Body (Top)	[h]	Compression spring	[n2]	O-Ring (B)	[5]	O-Ring (C)
[b]	Housing	[i]	Lock nut	[o]	Bolt, Nut, Washer	[6]	Stop ring*4
[c]	Diaphragm*1	[j]	Adjusting screw	[p]	Spring support plate*2	[7]	O-Ring (D)
[d]	Piston	[k]	Bolt, Washer*1	[q]	Pressure gauge		
[e]	Piston base*2	[l]	Cap	[2]	PJ-Body*3		
[f]	Spring plate	[m]	Ring seal	[3]	End connector		

*1; Used for V82

*2; Used for V182

*3; Part for self control valve

*4; Used for flange type

○ Pressure Relief Type

V185 (15mm~50mm { 1/2"-2" })

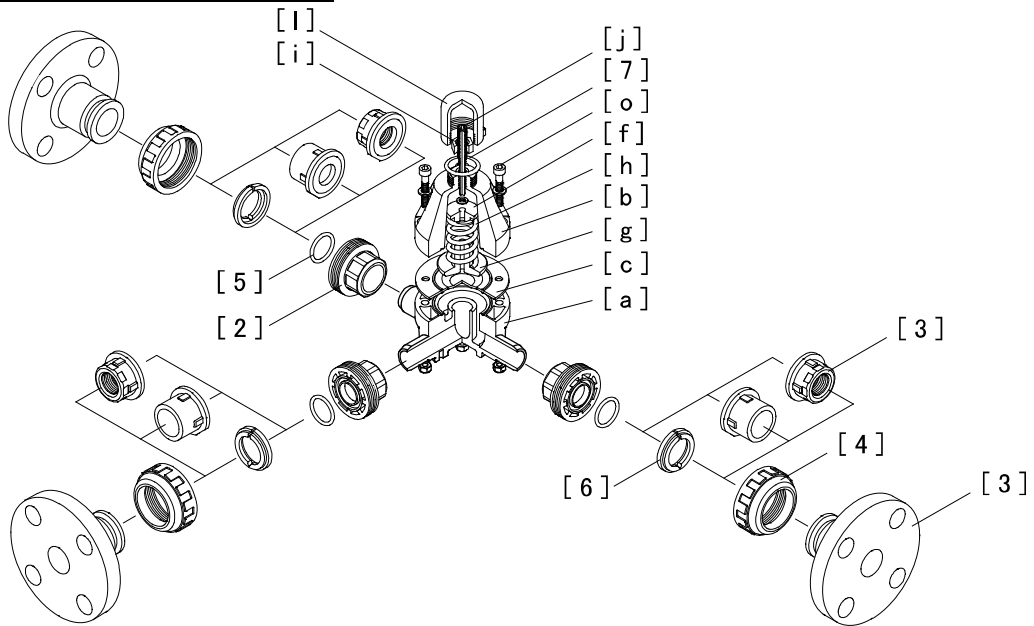

No.	Description	No.	Description	No.	Description	No.	Description
[a]	Body	[g]	Compressor	[1]	Cap	[4]	Union nut
[b]	Housing	[h]	Compression spring	[o]	Bolt, Nut, Washer	[5]	O-Ring (C)
[c]	Diaphragm	[i]	Lock nut	[2]	PJ-Body* ¹	[6]	Stop ring* ²
[f]	Spring plate	[j]	Adjusting screw	[3]	End connector	[7]	O-Ring (D)

*1; Part for self control valve *2; Used for flange type

○ Pressure Retaining Type

V186 (15mm~50mm { 1/2"-2" })

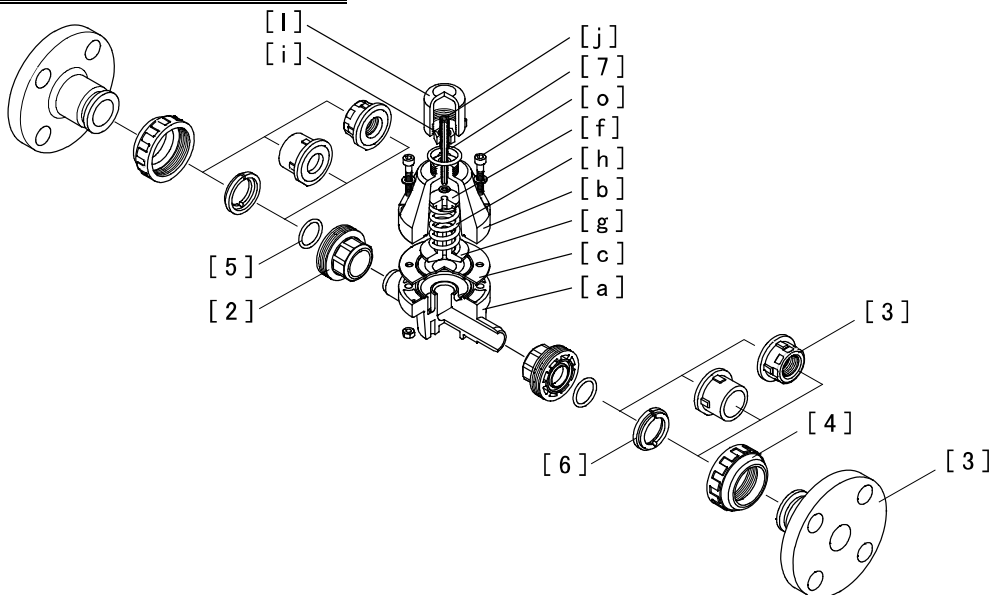

No.	Description	No.	Description	No.	Description	No.	Description
[a]	Body	[g]	Compressor	[1]	Cap	[4]	Union nut
[b]	Housing	[h]	Compression spring	[o]	Bolt, Nut, Washer	[5]	O-Ring (C)
[c]	Diaphragm	[i]	Lock nut	[2]	PJ-Body* ¹	[6]	Stop ring* ²
[f]	Spring plate	[j]	Adjusting screw	[3]	End connector	[7]	O-Ring (D)

*1; Part for self control valve *2; Used for flange type

5. Product functions and specifications

Functions

- The pressure reducing type (V182/V82) maintains a constant working pressure regardless of changes or fluctuations in inlet pressure. Upon changes in pressure, the diaphragm either lifts against the internal spring or is pressed down by the spring force until a state of equilibrium is re-established.

- The pressure relief type (V185) serves to keep the system pressure constant by balancing out pressure pulsations and reducing pressure peaks. The third pipe (right angle to the piping) is installed directly in the main pipeline (horizontal direction) through the pressure relief valve body. Fluid normally passes through the main pipeline of the valve, and if the inlet pressure rises above the set value, the valve piston lifts against the internal spring. Consequently, the valve opens and flow will pass through the perpendicular leg until the inlet pressure begins to drop. When the inlet pressure drops below the set pressure, the spring pushes against the valve piston until the valve closes and resumes normal operation.

- The pressure retaining type (V186) serves to keep the upstream system pressure constant. If the inlet pressure rises above the set value, the valve piston is lifted against the internal spring. The valve closes as soon as the inlet pressure sinks below the pre-set spring tension.

Specifications

	Pressure Reducing Type		Pressure Relief Type	Pressure Retaining Type
Type	V182	V82	V185	V186
Nominal size	15-40mm (1/2"-1 1/2")	50mm (2")	15-50mm (1/2"-2")	15-50mm (1/2"-2")
Rubber material	EPDM, FKM	FKM (PTFE coted) *2	EPDM, FKM (PTFE coted) *2	
Body material	PVC			
End connectors	Flanged end, Socket end, Threaded end			
Max. working pressure *1	1.0MPa {10.2 kgf/cm ² } [150 PSI] at 20°C (70°F)			
Working temperature	0-50°C (32-122°F)			
Adjustment range on outlet	0.1-0.9MPa [14.5-130 PSI]			

*1; Refer to the page of "Working pressure VS Temperature".

*2; Material of O-ring is FKM.

6. Maximum working pressure vs. temperature

- Pressure Reducing Type (V182, V82), Pressure Relief Type (V185), Pressure Retaining Type (V186)

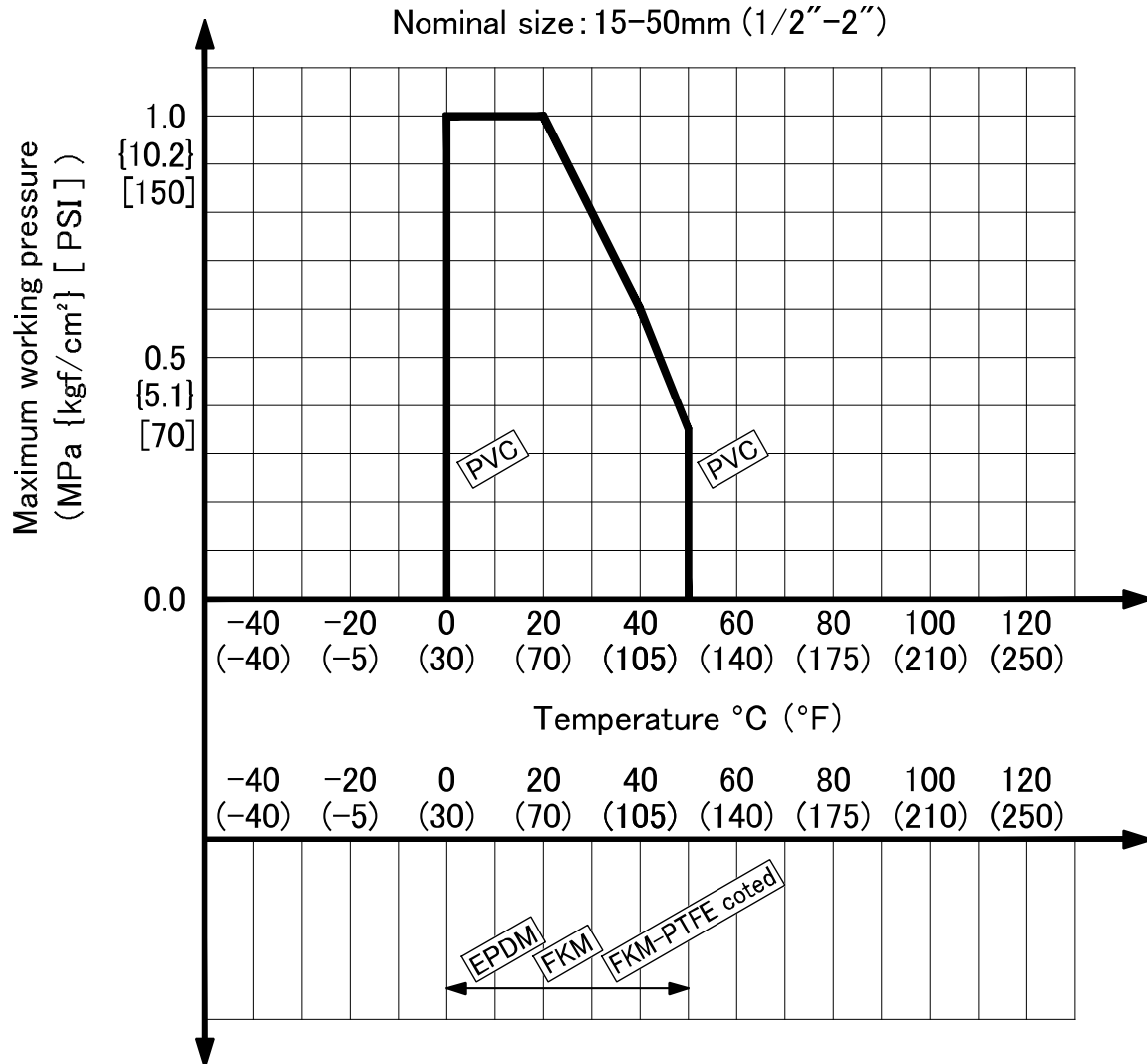

7. Valve flow characteristic

- Pressure Reducing Type (V182)

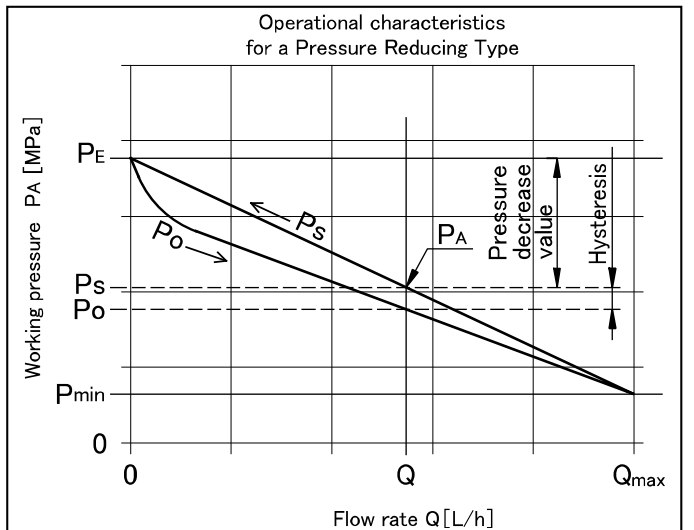
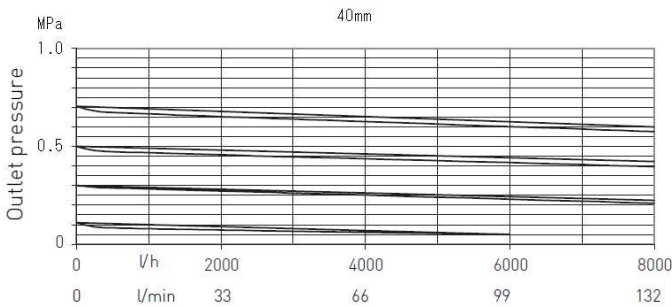
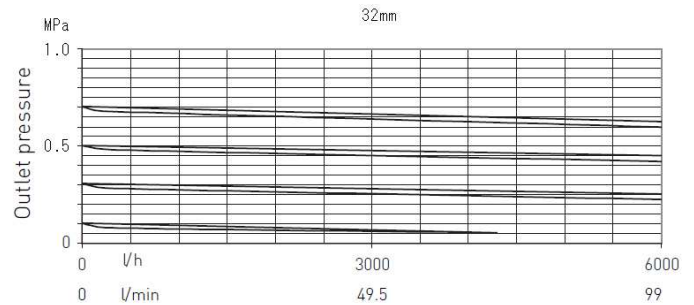
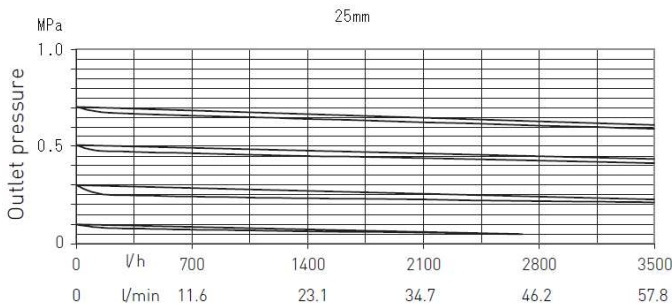
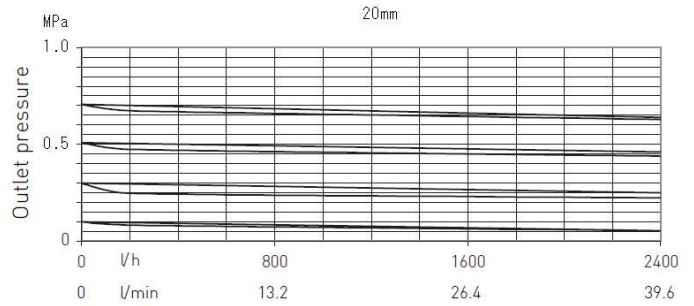
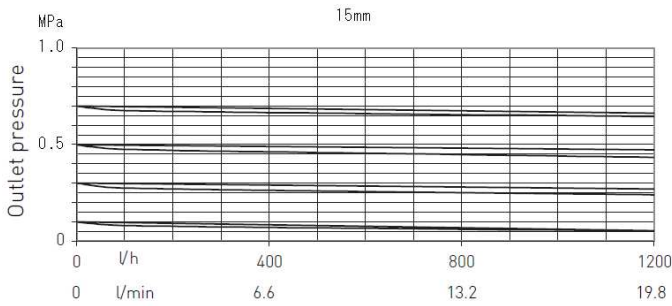

- Pressure Reducing Type (V82)

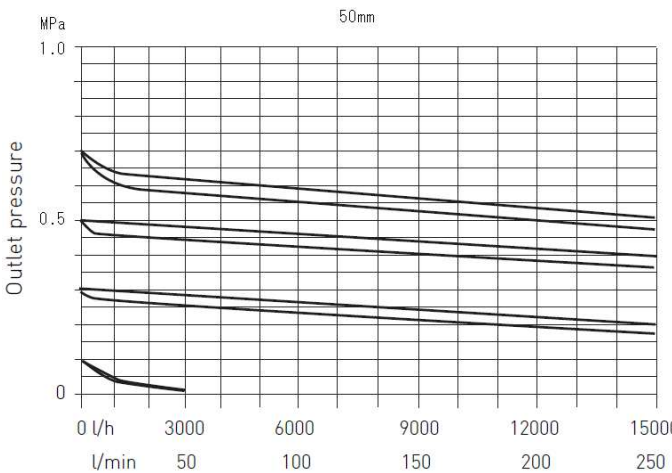

- The friction coefficient increases with the flow rate and the outlet pressure decreases.

P_E : Set pressure (at a flow rate of 0 L/h)

$P_E - P_{min}$: Max. pressure reduction value

- The set pressure is set at P_E . If the flow rate is increased to Q , the outlet pressure will decrease to P_O .

P_O line : Opening pressure characteristic. (Flow rate increasing)

P_S line : Closing pressure characteristic. (Flow rate decreasing)

Hysteresis : The flow rate is affected by the influence of the spring, piston and diaphragm in the valve. The working pressure is also a function of these parts, and will change depending on whether the flow rate is increasing or decreasing.

- Pressure Relief Type (V185), Pressure Retaining Type (V186)

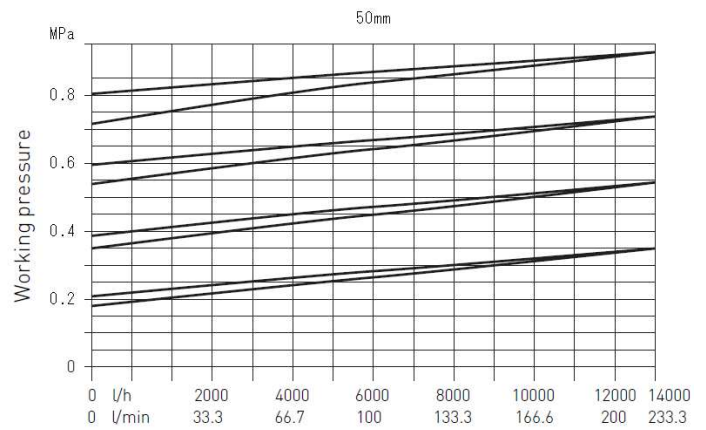
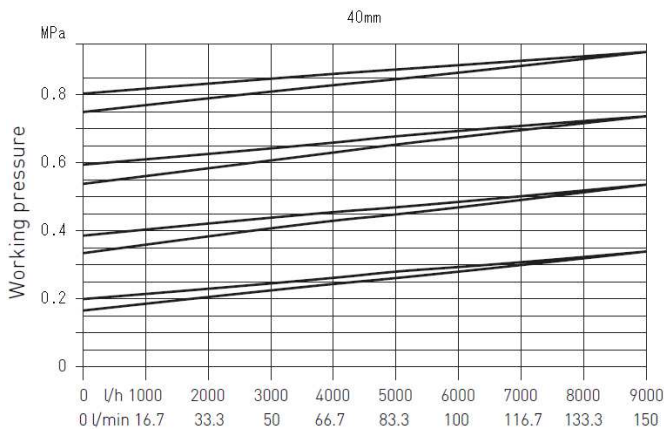
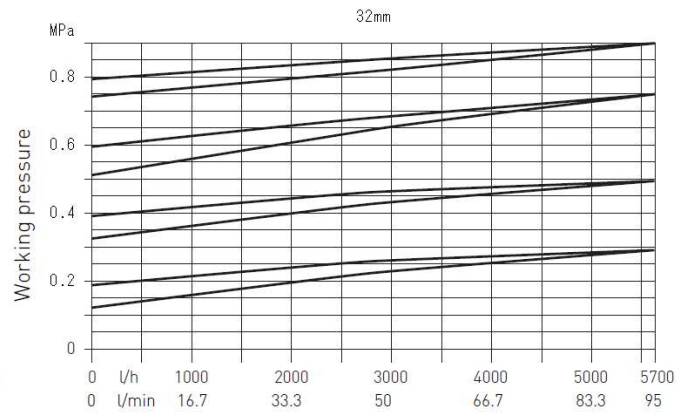
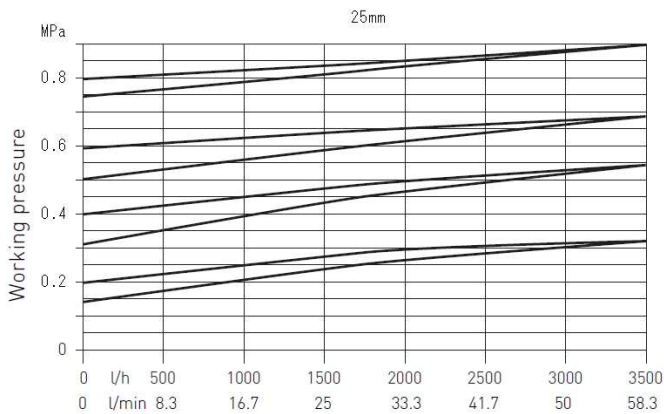
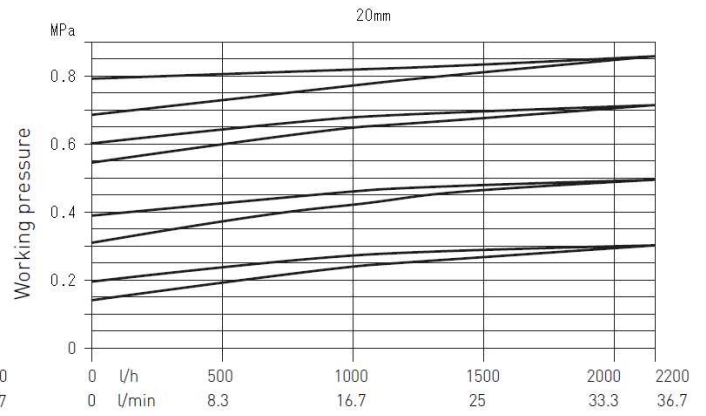
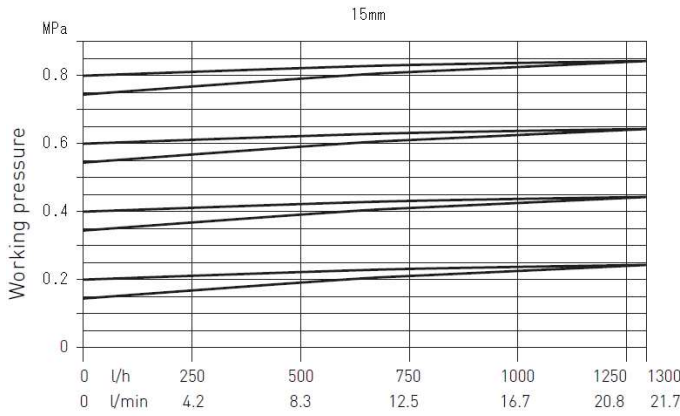

**Operational characteristics
for a Pressure Relief Type and Pressure retaining type**

- The friction coefficient and inlet pressure increase with the flow rate.
- P_E : Set pressure (at a flow rate of 0 L/h)
- P_A : Working pressure
- P_S : Closing pressure. (At a flow rate of 0 L/h)
- The set pressure is adjusted to P_E at a flow rate of 0 l/h. If the flow rate is increased to Q , the outlet pressure will increase to P_A .
- P_O line : The change of inlet pressure (Flow rate increasing)
- P_S line : The change of inlet pressure (Flow rate decreasing)
- The outlet pressure is increased and decreased from P_O to P_S by increasing and decreasing the flow rate.

8. Installation procedure



Warning

– When suspending and supporting a valve, take care and do not stand under a suspended valve.



– Be sure to conduct a safety check on all hand and power tools to be used before beginning work.

– Wear protective gloves and safety goggles as fluid remain in the valve even if the pipeline is empty. (You may be injured.)



Caution

– When installing a pipe support by means of a U-band or something similar, take care not to over-tighten. (Excessive force may damage the pipe.)

– Take care not to over-tighten the Union Nut. (The valve can be damaged.)

– Do not use the pipe wrench. (The valve can be damaged.)



– Piping with care in the flow direction. (Align the flow direction with the arrow of the label.)

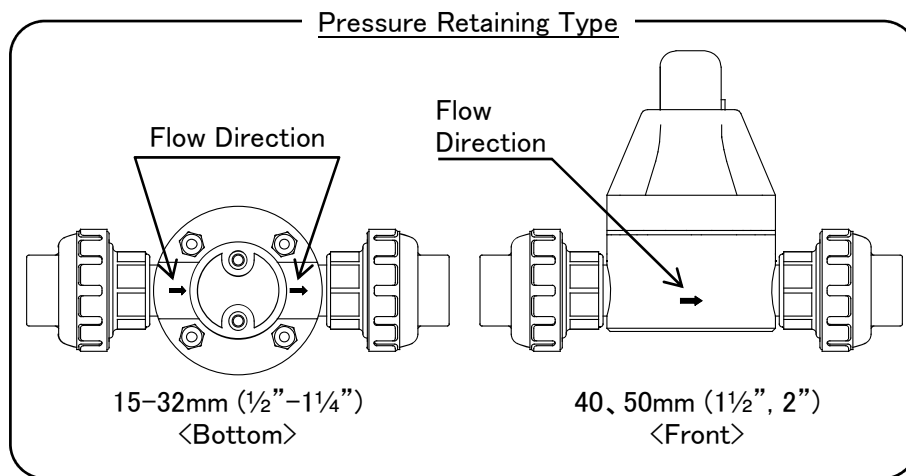
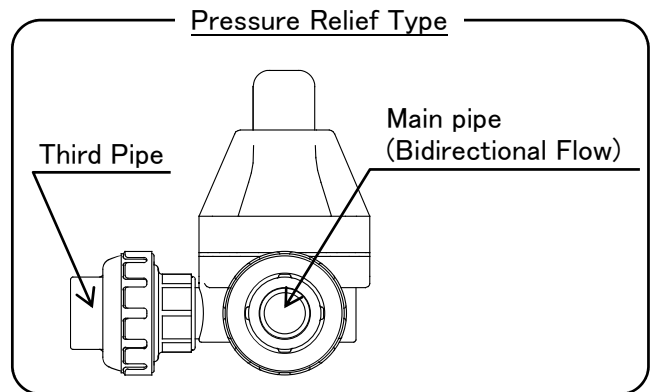
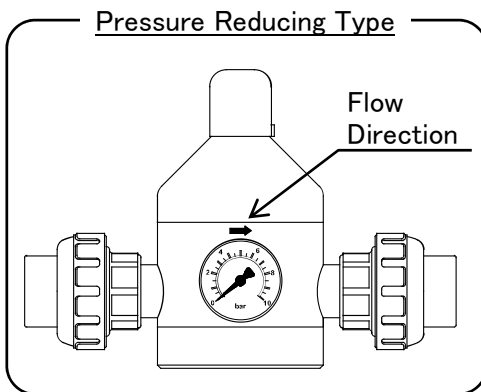

- The strainer should be installed in the upper stream line of the valve in order to avoid the malfunction possibility caused by clogging of the valve by foreign matters.
- When installing pipes and valves, ensure that they are not subjected to tension, compression, bending, impact, or other excessive stress.
- Before a water test, be sure that the Union Nut is tightly fastened.
- Fasten the Union Nut while avoiding the parallelism and axial misalignment of the flange surface.
- When connecting a ASAHI AV Valve to metal piping, take care not to let the pipe stress on the ASAHI AV Valve.

Flanged End



- Use flat faced flanges for connection to AV Valves.
- Ensure that the mating flanges are of the same standards.
- Be sure to use sealing gaskets (AV Gasket), bolts, nuts, and washers and tighten them to specified torques. (When a non-AV gasket is used, a different tightening torque instruction should be followed.)

Necessary items

- Torque wrench
- AV gasket

Procedure

- 1) Set the AV gasket between the flanges.
- 2) Insert washers and bolts from the pipe side, insert washers and nuts from the valve side, then temporarily tighten by hand.



- The parallelism and axial misalignment of the flange surface should be under the values shown in the following table to prevent damage the valve. (A failure to observe them can cause destruction due to stress application to the pipe.)

Nominal size	Axial misalignment	Parallelism (a-b)
15-32mm (1/2"-1 1/4")	1.0mm (0.04")	0.5mm (0.02")
40, 50mm (1 1/2"-2")	1.0mm (0.04")	0.8mm (0.03")

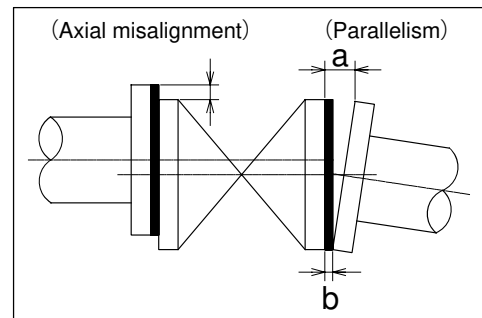

- 3) Tighten the bolts and nuts gradually with a torque wrench to the specified torque level in a diagonal manner.
- 4) Tighten it more than 2 turns clockwise with specified torque.



- Do not tighten above the specified torque value. (The valve can be damaged or leaks.)

Specified torque value

Unit: N·m {kgf·cm} [lb·inch]

Nominal size	15mm (1/2")	20mm (3/4")	25mm (1")	32mm (1 1/4")	40mm (1 1/2")	50mm (2")
PTFE coted	17.5 {179}	17.5 {179}	20.0 {204}	20.0 {204}	20.0 {204}	22.5 {230}
PVDF coted	[155]	[155]	[177]	[177]	[177]	[200]
Rubber	8.0 {82} [71]	8.0 {82} [71]	20.0 {204} [177]	20.0 {204} [177]	20.0 {204} [177]	22.5 {230} [200]

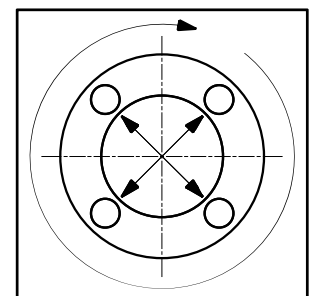

* When union nut is loosened or removed, please install in the following way.

- 5) Make sure that the O-ring (C)[5] is mounted.
- 5) Set the end connector and union nut directly on the body without allowing the O-ring (C) to come off.
- 7) Tighten union nut on each valve until hand tight.
- 8) Using a strap wrench tighten union nuts[4] uniformly on each side approx. 90°- 180° turns, 1/4 to 1/2 turns.



Caution

– Avoid excessive tightening. (The valve can be damaged.)



- The union nut of this product is fastened lightly so that it can be loosened easily. Be sure to remove the end connector before carrying out the work. (Failure to do so may cause external leakage.)
- Make sure that the threaded connections are plastic x plastic. (Metallic thread can cause damage.)
- Wrap the threaded joints on our plastic piping with sealing tape. Using a liquid sealing agent or liquid gasket may cause stress cracks (Environmental Stress Cracking). Our product warranty shall not apply in case of said use, even when said use is unavoidable.

Necessary items

● Sealing tape







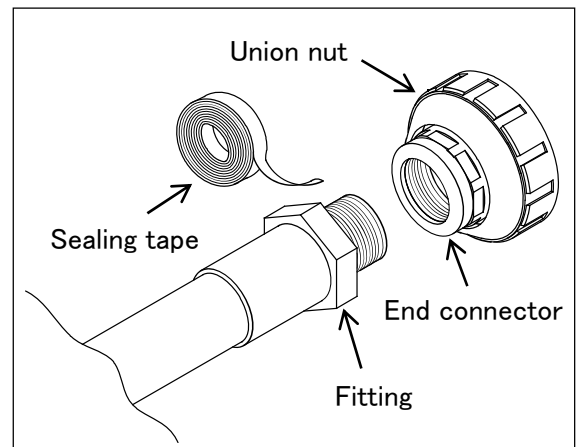

● Strap wrench

● Spanner wrench

Procedure

- 1) Wind a sealing tape around the external thread of joint, leaving the end (about 3mm) free.
- 2) Loosen the union nut with a strap wrench.
- 3) Remove the union nut and end connector from the body.
- 4) Tighten the external thread of the joint and the end connector hardly with hand.
- 5) Using a spanner wrench, screw in the end connector by turning 180° -360° carefully without damaging it.
- 6) Make sure that the O-ring (C) is mounted.
- 7) Set the end connector and union nut directly on the body without allowing the O-ring (X) to come off.
- 8) Tighten union nut on each valve until hand tight.
- 9) Using a strap wrench tighten union nuts uniformly on each side approx. 90°- 180° turns, 1/4 to 1/2 turns.



-   - When using an adhesive, ventilate the space sufficiently, prohibit the use of a fire in the vicinity, and do not inhale adhesive vapors directly.
-  - If an adhesive gets into contact with your skin, wash it off immediately. If you feel sick or find anomaly, receive a physician's diagnosis and take appropriate measures promptly.
-   - Do not under any circumstances try to insert a pipe into another fitting or valve by striking it. (Which may break the piping.)
-   - Take care in doing work at low temperatures. Solvent vapors are hard to evaporate and are likely to remain. (Solvent cracks may occur, damaging the equipment.) After assembling the piping system, open both ends of the piping and use a fan (of the Low-pressure Type) or something similar to ventilate the space, thus removing the solvent vapors.
-  - The union nut of this product is fastened lightly so that it can be loosened easily. Be sure to remove the end connector before carrying out the work. (Failure to do so may cause external leakage.)
- Use the appropriate ASAHI AV cement.
- Conduct a water test at least 24 hours after joining the pipes with an adhesive.



Necessary items

- ASAHI AV cement
- Strap wrench

Procedure

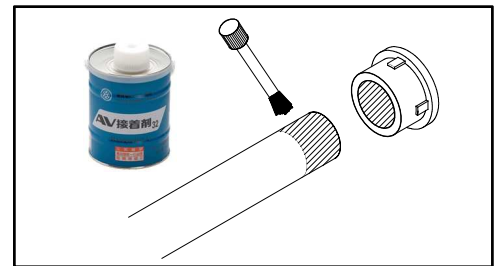
- 1) Loosen the union nut with a strap wrench.
- 2) Remove the union nut and end connector from the body.
- 3) Lead the union nut through the pipe.
- 4) Make sure the hub part of the end connector is clean with waste cloth.
- 5) Apply adhesive evenly to the hub part of the end connector and the pipe spigot.



-   - Do not apply more adhesive than necessary. (The valve can be damaged due to solvent cracking.)

Adhesive quantity (guideline)

Nominal size	15mm (1/2")	20mm (3/4")	25mm (1")	32mm (1 1/4")	40mm (1 1/2")	50mm (2")
Quantity (g)	1.0	1.3	2.0	2.4	3.5	4.8

- 6) After applying adhesive, insert the pipe quickly to the end connector and leave it alone for at least 60 seconds.
- 7) Wipe away overflowing adhesive.
- 8) Make sure that the O-ring (C) is mounted.
- 9) Set the end connector and union nut directly on the body without allowing the O-ring (C) to come off.
- 10) Tighten union nut on each valve until hand tight.
- 11) Using a strap wrench tighten union nuts uniformly on each side approx. 90°- 180° turns, 1/4 to 1/2 turns.

9. Adjustment procedure for working pressure



Caution

- Tighten the lock nut securely. (Too weak a tightening torque on a lock nut may cause it to loosen.)
- When the adjusting screw keeps being turned counterclockwise, it comes off. Therefore, handle it within a range that it will not come off.

Necessary items

- Spanner wrench
- Allen wrench

Procedure

- 1) Detach the cap [i] from the top of the valve.
- 2) Loosen the lock nut [i] counterclockwise with a spanner wrench.
- 3) Turn the adjusting screw [j] with an Allen wrench.
 - Clock wise: The working pressure is increased.
 - Counterclockwise: The working pressure is decreased.
- 4) Set the adjusting screw [j] with an Allen wrench, and use spanner wrench to tighten the lock nut [i].
- 5) Re-attach the cap [i].
 - When the cap [i] touches the O-ring (D) [7], turn the cap [i] about 45° to closing degree.

10. Disassembling method for replacing parts



Warning

– When replacing valves and parts, completely eliminate pressure in the pipe.



Caution

– When conducting piping work, wear personal protective equipment appropriate to the contents of work. (Failure to do so may cause an injury.)

– When disassembling the valve, unlock the adjustment screw until the compression spring is discharged. (You may be injured.)



Caution

– Do not take the pressure gauge apart.

Gauge contains a buffer fluid (between gauge and diaphragm) which will leak if the gauge is disassembled.

– A socket wrench for disassembling the body part requires special jig (Optional item) according to model and size. For details, please consult the nearest sales office.

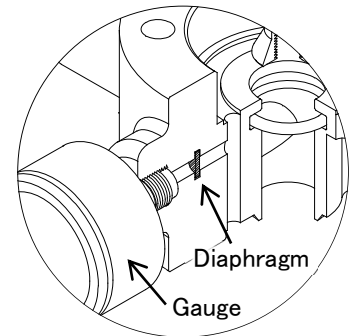

Necessary items

- Safety goggles
- Protective gloves
- Spanner wrench
- Allen wrench
- Socket wrench
- special jig (Optional item)

Pressure Reducing Type (V182)

Disassembly Procedure

- 1) Remove the cap [i] from the top of the housing [b].
- 2) Loosen the lock nut [i] counterclockwise with a spanner wrench and the adjusting screw [j] counterclockwise with an Allen wrench.
- 3) Loosen the bolt [o] and remove the body (bottom) [a1] and body (top) [a2] from the housing [b].
- 4) Remove the compression spring [h] and the spring plate [f].
- 5) Remove the piston base [e] counterclockwise from the piston [d].
- 6) Push up and remove the piston [d] from the bottom of the body (top) [a2]

Assembly procedure

Follow above steps in reverse to assemble valve. (Apply appropriate amounts of silicone grease to O-rings before assembly.)

Pressure Reducing Type (V82)

Disassembly Procedure

- 1) Remove the cap [i] from the top of the housing [b].
- 2) Loosen the lock nut [i] counterclockwise with a spanner wrench and the adjusting screw [j] counterclockwise with an Allen wrench.
- 3) Loosen the bolt [o] with the Allen wrench and remove the body (bottom) [a1] and body (top) [a2] from the housing [b].
- 4) Remove the compression spring [h] and spring plate [f].
- 5) Loosen bolt [k] with the Allen wrench and remove the compressor [g] and diaphragm [c].
- 6) Pull out the piston [d] from the bottom of the body (top) [a2].

Assembly procedure

Follow above steps in reverse to assemble valve. (Apply appropriate amounts of silicone grease to O-rings before assembly.)

Tightening torque of the bolts

Unit: N·m {kgf·cm} [lb·inch]

Nominal size	15mm (1/2")	20, 25mm (3/4", 1")	32, 40mm (1 1/4", 1 1/2")	50mm (2")
Torque Value	9 [92] [80]	12 [122] [106]	15 [153] [133]	29 [296] [257]

Pressure Relief Type / Pressure Retaining Type (V185 / V186)

Disassembly Procedure

- 1) Remove the cap [i] from the top of the housing [b].
- 2) Loosen the lock nut [i] counterclockwise with a spanner wrench and the adjusting screw [j] counterclockwise with an Allen wrench.
- 3) Remove the covering caps on bolt [o], and loosen bolt [o] counterclockwise with an Allen wrench.
- 4) Remove the compression spring [h] and spring plate [f].
- 5) Remove the diaphragm [c] from the body [a].

Assembly procedure

Follow above steps in reverse to assemble valve. (Apply appropriate amounts of silicone grease to O-rings before assembly.)

Tightening torque of the bolts

Unit: N·m {kgf·cm} [lb·inch]

Nominal size	15, 20mm (1/2", 3/4")	25, 32mm (1", 1 1/4")	40, 50mm (1 1/2", 2")
Torque Value	9 [92] [80]	12 [122] [106]	20 [204] [177]

11. Inspection items



– Perform periodic maintenance. (Leakage may develop due to temperature changes or over periods of prolonged storage, rest or operation.)

* Inspect the follow items

(1)	Check for any flaw, cracks, or deformation on the outside of valve.
(2)	Check for fluid leaking out of the body of the valve.
(3)	Check the tightness of bolts, nuts, and lock nuts.
(4)	Check the tightness of Union nuts.
(5)	Check to ensure the adjusting screw operates smoothly.

12. Troubleshooting

Problem	Cause	Treatment
Fluid leaks from the body and the housing.	The bolt [o] has loosened.	Tighten up the bolt.
	The diaphragm and/or O-ring (A, B) have failed.	Replace the diaphragm and/or O-ring.
Fluid leaks from the union nut.	The union nut is loosened.	Tighten up the union nut.
	The O-ring (C) has failed.	Replace the O-ring with a new one.
Fluid leaks from the adjusting bolt.	The diaphragm has failed.	Replace the diaphragm with a new one.
	The O-ring (B) has failed.	Replace the O-ring with a new one.
The outlet pressure is below the set value.	The piston base and/or the ring seal have failed.	Replace the piston base and/or ring seal with new ones.
	The diaphragm and/or weir have failed due to abrasion or scratches.	Replace the parts or the product.

– It is necessary to replace failed parts in order for the valve to perform properly. Refer to below parts list for an explanation of available parts kits.

Type	Parts Name	Description
Pressure Reducing Type	Adjustment Kits	V182 Adjusting Screw [j], Spring Plate [f], Compression Spring [h], Spring Support Plate [p], Piston [d] and Piston Base [e]
		V82 Adjusting Screw [j], Spring Plate [f], Compression Spring [h], Piston [d] and O-ring (B) [n2]
	Sealing Kits	V182 O-ring (A) [n1], O-ring (B) [n2], Ring Seal [m]
		V82 Diaphragm [c], O-ring (A) [n1], Ring Seal [m]
Pressure Relief Type Pressure Retaining Type *1	Spare Parts Sets	Adjusting Screw [j], Diaphragm [c] Compression Spring [h]
All Types *2	O-ring	O-ring (C)[5]
	End Connector / Union Nut	End Connector [3], Union Nut [4], Stop Ring [6] (Used for Flanged End.)

*1. Pressure Relief Type and Pressure Retaining Type use the same parts.

*2. The parts listed in this row are compatible with pressure reducing type, pressure relief type, and pressure retaining type.

13. Handling of residual and waste materials



– Make sure to consult a waste treatment dealer for recommendations on the proper disposal of plastic valves. (Poisonous gas is generated when the valve is burned improperly.)

Self Control Valves

Pressure Reducing Type / Pressure Relief Type / Pressure Retaining Type

15-50mm (1/2"-2")

ASAHI YUKIZAI CORPORATIONDistributor<http://www.asahi-yukizai.co.jp/en/>